

ELECTRIC ACTUATOR

E024, E025, E026, E029 & E030

Installation Operation and Maintenance Instructions



TABLE OF CONTENTS

Electric Actuator Specifications.....	2
Overview	3
Actuator Wiring Diagrams.....	4
VMS-35 Specifications and Wiring Diagram	5
VMS -35 Installation and Testing.....	6
VMS -35 Battery Replacement	7
Removal of E024 & E025	8
Installation of E024 & E025	9
Removal of E026, E029 & E030.....	10
Installation of E026, E029 & E030.....	11
Set-up	12
Control Action	13
Power Failure Direction E025 & E026	14
Indicator Lights	15
Installation Drawings	16-17
Addendum.....	18-20

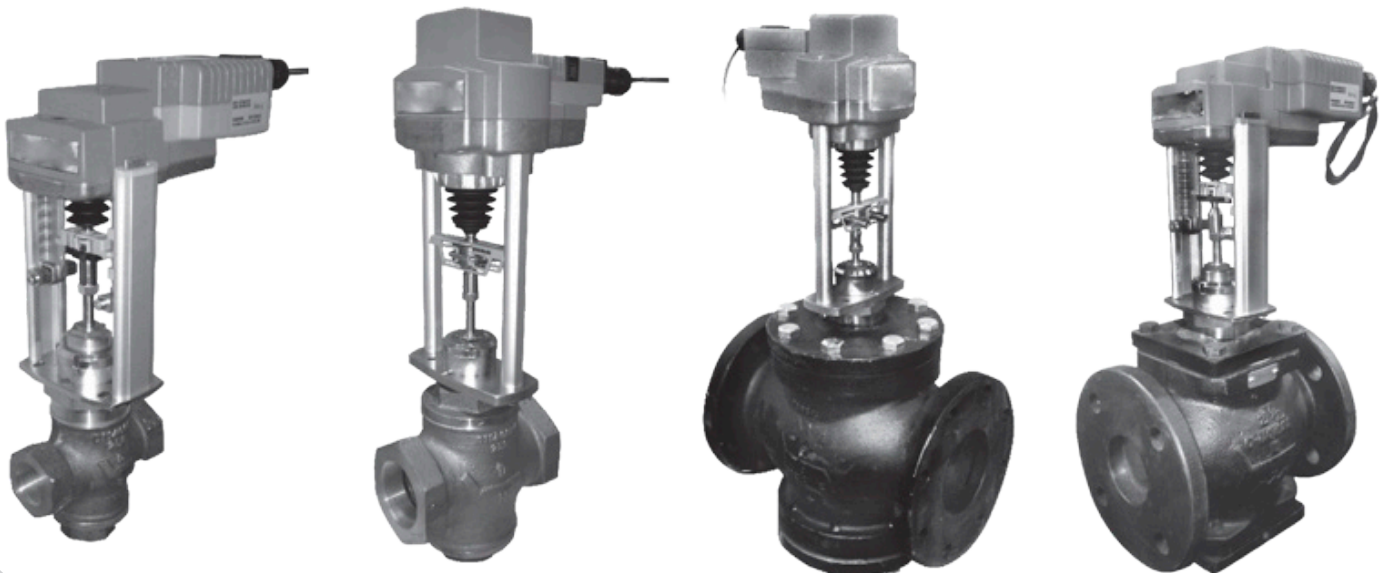

ELECTRIC ACTUATOR SPECIFICATIONS *

Valve Usage:	E024, E025 E026 E029, E030	[Valve sizes 1/2 to 4 Inch] [Valve sizes 1 to 6 Inch] [Valve sizes 1-1/4 to 10 Inch]
Power supply:	24 VAC ± 20% 50/60 Hz, 24 VDC ± 10%	
Transformer Sizing: (24VAC Class 2)	E024 E025, E026 E029 E030	6 VA 21 VA 10 VA 50 VA (Actuator 10VA, VMS-35 40VA)
Timing:	90 seconds full stroke max	
Control Signal:	2-10 Vdc (default), 4-20 mAdc [with KR500 (resistor kit)]	
Feedback Signal:	2-10 Vdc	
Signal Failure Direction:	E024, E029, E030 E025, E026	Fail Closed or Lower Port Closed (default), or Fail Open or Upper Port Closed Fail Closed or Lower Port Closed (default), or Fail Open or Upper Port Closed
Power Failure Mode:	E024, E029 E030 E025, E026	Fail-In-Place Fail-Safe to Signal Failure Direction Fail Closed or Lower Port Closed (default), or Fail Open or Upper Port Closed
Capacitor:	E025, E026	Capacitor charge time 5 to 20 seconds
Manual Override:	Yes, with supplied Allen Key (4mm E024, E025 / 5mm, E026, E029, E030)	
Construction:	Aluminum die cast Yoke, plastic Housing	
Connections:	3 foot long 4 Conductor 18 gauge wire, pigtail (may include fifth pink colored conductor only used for factory programming. Do Not Use or Connect)	
Enclosure Type:	NEMA 2, IP54, UL 2	
Noise Level:	E024, E025 E026 E029, E030	45 dBA 60 dBA 65 dBA
Environmental:	Operating: Ambient + 32°F to +122°F (0 to +50°C) Humidity: 5 to 95% RH non-condensing Storage: -40°F to +176°F [-40°C to +80°C]	
Orientation:	Factory Aligned per drawings	
Mounting:	Vertical above centerline of valve	
Safety Agency Listing:	CE, cULus	

* See page 5 for VMS-35 Specifications

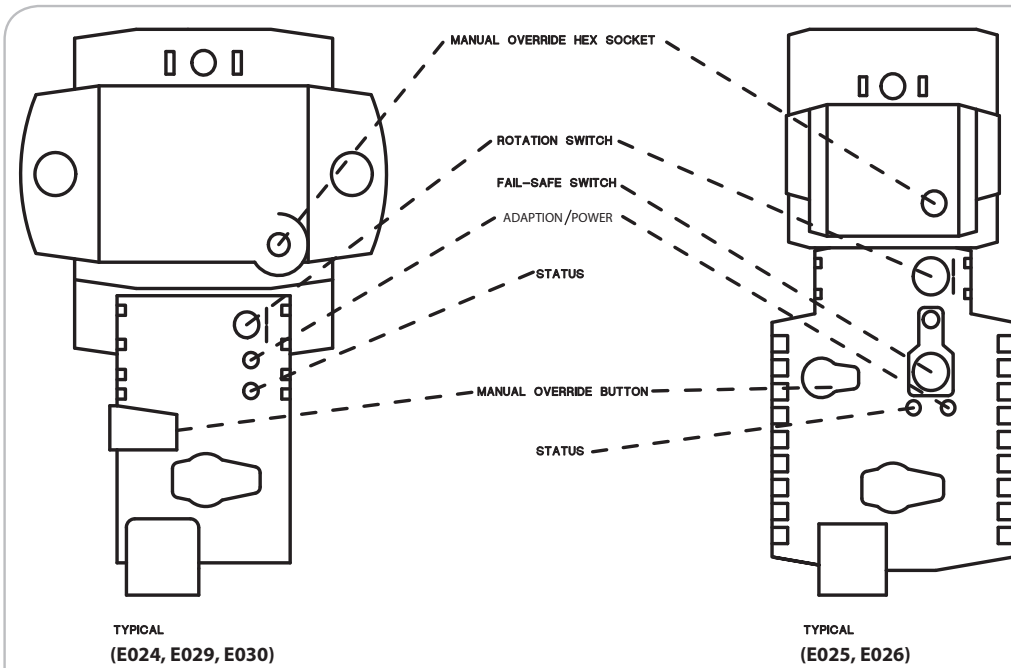

The actuators feature a native 2-10 Vdc Control Signal. Installation of the KR500 Resistor Kit converts the Control Signal input to **4-20 mAdc**. When using 4-20 mA input, terminate the 500 ohm resistor from the KR500 resistor kit between the White and Black actuator wires. When using the VMS-35, this can be easily done between the NO1 and LN terminals for Actuator 1 and between the NO2 and LN terminals for Actuator 2.

A single wire brings a 2-10 Vdc Feedback Signal. The Feedback Signal is not available using 4-20 mAdc.

Manual Override is possible by turning off the power, pressing the Manual Override button and rotating the supplied Allen key in the Socket.

To raise the actuator stem turn the Allen key counter-clockwise.

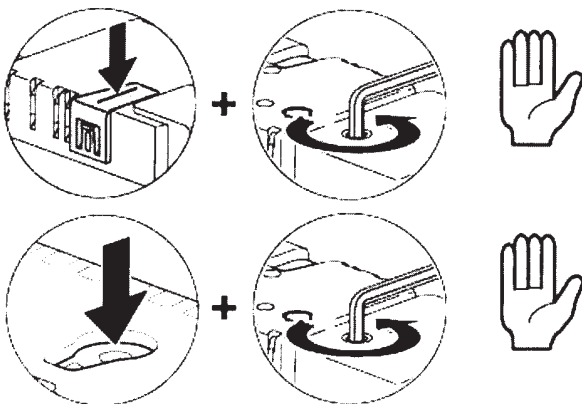

To lower the actuator stem turn the Allen key clockwise.

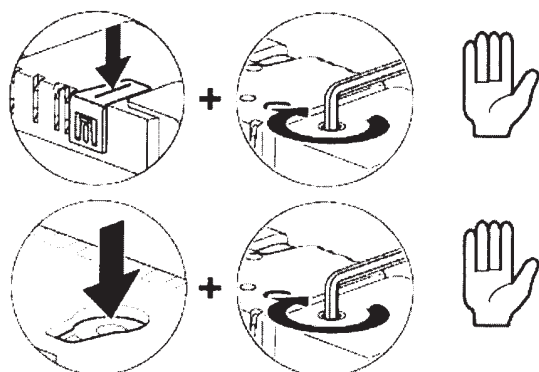

DANGER

PRESS THE MANUAL OVERRIDE BUTTON IN FIRMLY WHILE OPERATING THE MANUAL OVERRIDE. FAILURE TO DO SO WHILE THE ACTUATOR IS POWERED OR BEING DRIVEN TO THE POWER FAILURE DIRECTION CAN CAUSE SERIOUS PERSONAL INJURY AND DAMAGE THE ACTUATOR.

The Rotation Switch can be adjusted to set the direction the Control Signal opens and closes the valve (and Loss of Signal direction in some actuators) in the field without actuator removal.

Adaption (Auto-Calibration - green LED), a combined Adaption/ Power button to reset and relearn the valve stroke as well as indicate the actuator is powered. When the Button is pressed, the actuator will drive one full cycle to its mechanical end stops OR the valves mechanical seats. Upon completion of this cycle the actuators working range (Control Signal, Feedback Signal and running time) will be adjusted to the actual stroke of the actuator.

Status (yellow LED) to confirm communication.

ACTUATOR WIRING DIAGRAMS

2-10 VDC

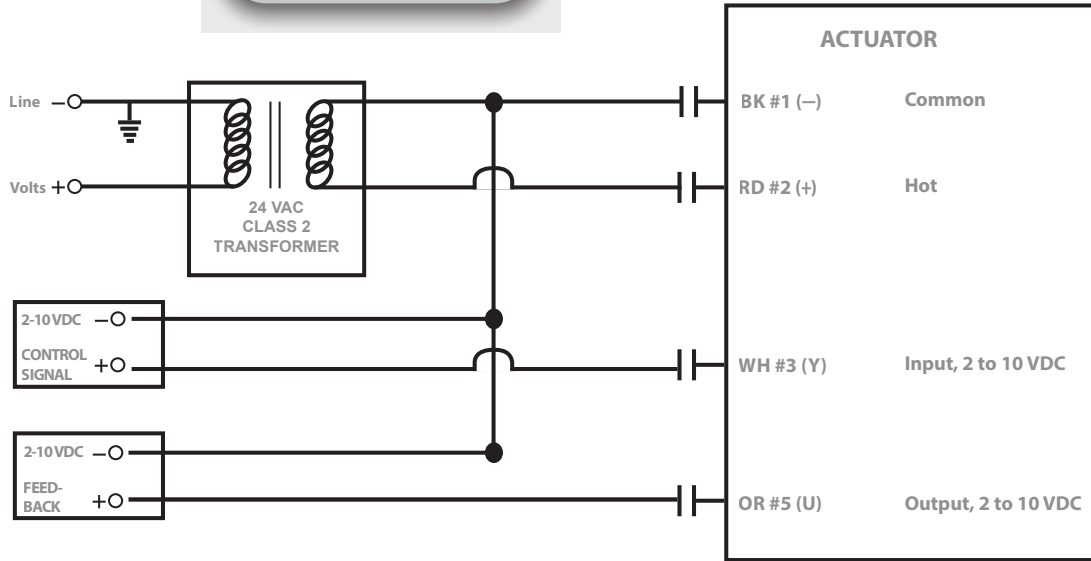

4-20 MADC

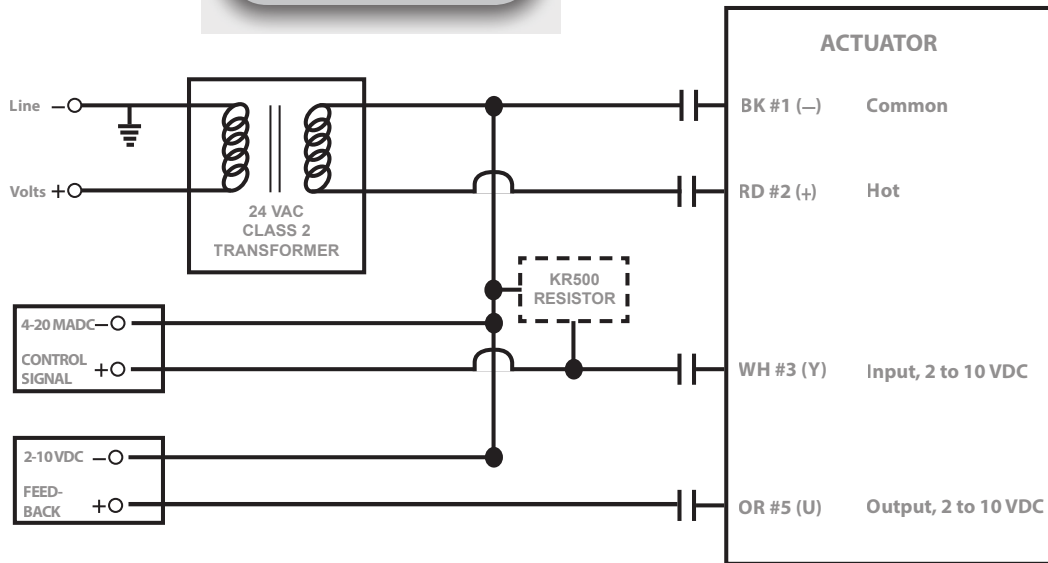

VMS-35 BCM (BACK-UP CONTROL MODULE) SPECIFICATIONS

Actuator Usage:	E030 (E030 includes a VMS-35 BCM), E029, E024
Power supply:	24 VAC ± 20% 50/60 Hz
Power Consumption:	40 VA (add VA rating for actuator used)
Number Actuators:	One or Two
Construction:	Battery w/Circuit Board, Charger and Transformer
Enclosure Type:	NEMA 4X, IP66, UL 4X, CSA 4X
Flame Retardant:	UL 50
Construction:	UV Stabilized Fiberglass Reinforced Polyester, Polycarbonate Hinge and Closed Cell Neoprene Gasket
Connections:	Two 1/2 IN conduit with one plug
Number Batteries:	One
Initial Charge:	2-4 hours
Battery Life:	Up to 5 years ... Replacement battery model UB1213 / 12V, 1.3 Ah
Mounting:	Feet for Wall Mount (4.91" x 8.75" centers)
Environmental:	<i>Operating/Storage:</i> Ambient +32°F to +104°F (0 to +40°C) – due to battery
Weight:	4.25 lbs (2 kg)
Safety Agency Listing:	Not listed

VMS-35 WIRING DIAGRAM

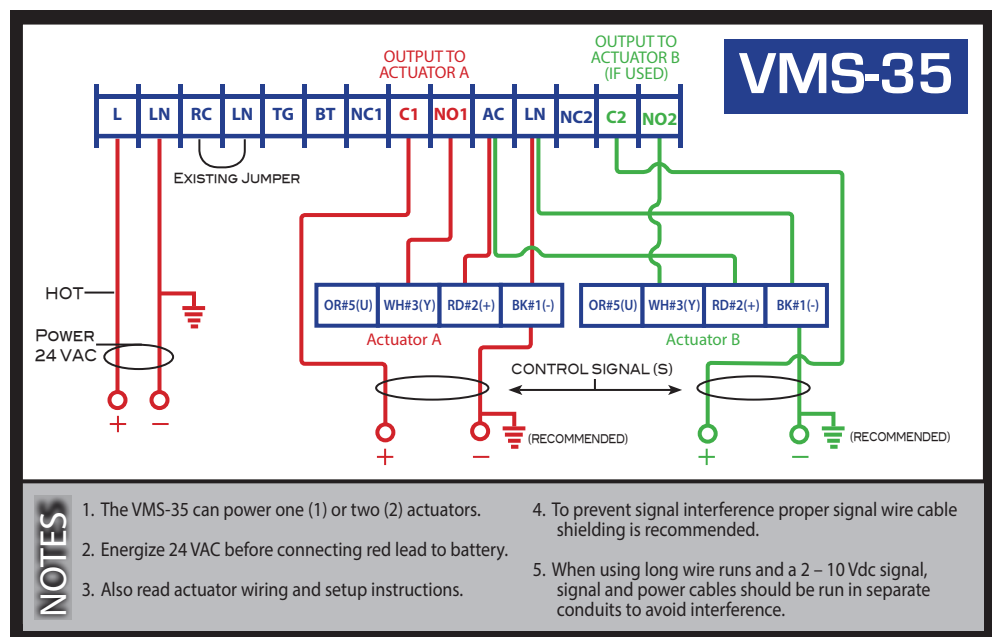

TERMINALS

L	System Power 24 VAC (+)
LN	System Neutral (-)
RC	Remote Control
BT	Battery Test (+)
TG	Test Ground (-)
C1	Control Signal 1st Actuator (+)
C2	Control Signal 2nd Actuator (+)
NC1	Not Used
NC2	Not Used
NO1	Relay Normally Open 1st Actuator
NO2	Relay Normally Open 2nd Actuator
AC	24 VAC Out (+)

Operation:

Proportional Normal: Terminal L is connected to 24 VAC building power. Terminal LN completes the circuit to BK. Actuator responds to modulating input signal.

Power Failure: Terminal AC changes to 24 V square wave from battery/inverter. A relay breaks the connection between Terminals C1 and NO1 forcing the actuator to return to the rotation switch position (See page 11 for explanation of rotation switch position).

Loss of Signal: Terminal AC uses 24VAC building power. The control signal is broken forcing the actuator to return to the rotation switch position (See page 11 for explanation of rotation switch position).

INSTALLATION

1. Disengage the 24 VAC building power circuit before wiring. Verify that the battery inside the VMS-35 has its wires disconnected and leave them that way for now. Disconnect them if they are connected.

2. Connect the VMS-35 to the actuator(s) as shown on wiring diagram. The VMS-35 can power one or two actuators.

Actuator A: Connect terminal N01 to white wire from actuator to drive the valve stem to the rotation switch position. Connect terminal AC to red wire from actuator to provide power. Connect grounded reference – negative/black wire from actuator to terminal LN. Also connect the control signal (-) to the black wire from the actuator. Connect terminal C1 to the control signal positive (+). If the control signal is 4-20mADC a KR500 500 ohm resistor is required. Terminate the resistor between terminals N01 and LN.

Actuator B: Connect terminal N02 to white wire from actuator to drive the valve stem to the rotation switch position. Connect terminal AC to red wire from actuator to provide power. Connect grounded reference – negative/black wire from actuator to terminal LN. Also connect the control signal (-) to the black wire from the actuator. Connect terminal C2 to the control signal positive (+). If the control signal is 4-20mADC a KR500 500 ohm resistor is required. Terminate the resistor between terminals N02 and LN.

3. While still disconnected, wire the VMS-35 to 24 volts AC power. Connect the hot to terminal L then neutral to terminal LN.

4. Engage the 24 VAC building power.

5. Verify that building power is live then connect the loose red wire inside the VMS-35 enclosure to the positive (+) battery terminal and the black wire to the negative (-) battery terminal.

NOTE: Engage the 24 VAC power to the VMS-35 before connecting the battery. Connecting the battery first causes the VMS-35 to go into the power failure mode. If there are conditions other than power failure during which the actuator should be driven to the rotation switch position (See page 11 for explanation of rotation switch position), replace the jumper between RC & LN with a contact that opens on demand.

TESTING

Disconnecting the jumper between RC & LN, with building power on, will drive the actuator to the rotation switch position (See page 11 for explanation of rotation switch position).

Testing the VMS-35 and the charging system and battery is recommended yearly. To test charging measure the voltage between terminals TG & BT. TG is negative. When the power supply is charging correctly the voltage will be 13 - 14 volts DC. To test the battery disconnect LN or L, wait for the actuator to return to the rotation switch position (See page 11 for explanation of rotation switch position) and then measure the voltage between TG & BT. A good and adequately charged battery will be between 10 - 12 volts DC.

The VMS-35 is a standby power supply.

It is intended to drive an actuator to either open or close a valve during a power failure. The VMS-35 can power one or two actuators.

VMS-35 (UB1213) BATTERY REPLACEMENT



PROCEDURE:

NOTE Normal valve operation under 24 VAC power need not be interrupted during battery replacement; however, the fail-safe function will not be available until the new battery is in place, connected and sufficiently charged (typically 2-4 hours).

1. Refer to the picture (left) to locate and disconnect the Red and Black wires from the battery.
2. Remove the two battery mounting bracket screws and remove the battery and bracket.
3. Place the bracket over the new battery and install the assembly as shown, using the two screws removed in step 2 (above).
4. Connect the Black wire to the black (unmarked) terminal.
5. With 24 VAC power present, connect the Red wire to the red terminal. VMS-35 circuitry will automatically charge the battery. (If 24 VAC is not present, the valve may move to its fail-safe position, depending upon residual charge in the new battery.)
6. Recycle or dispose of the old battery properly. Do not incinerate!

READ ALL INSTRUCTIONS CAREFULLY BEFORE BEGINNING.

REMOVAL OF E024 & E025 ACTUATORS FROM VALVE

SEE DRAWING D3400024 on page 16

THESE INSTRUCTIONS TREAT THE ACTUATOR (ITEM 1) AND LINKAGE BASE (ITEM 17) AS AN ASSEMBLY. FOR INSTRUCTIONS ON HOW TO REMOVE THE ACTUATOR AND THE LINKAGE BASE AS SEPARATE ITEMS SEE THE ADDENDUM ON PAGE 18.

- 1) Remove line pressure and isolate valve in piping.
- 2) Operate actuator so plug is off seat(s) or travel stop in valve.
- 3) Remove power and signal from actuator. For E025, after power is removed, cycle Fail-Safe Switch from Up Arrow to Down Arrow until actuator stem no longer moves. Adaption/Power (green LED) changes from blinking to off. Return Fail-Safe Switch to original position. If necessary use the manual override to operate actuator so plug is off seat(s) or travel stop in valve.

WARNING: DO NOT FORCE OR TURN THE MANUAL OVERRIDE WHEN THE MANUAL OVERRIDE BUTTON IS NOT PRESSED. DOING SO MAY CAUSE DAMAGE TO THE ACTUATOR GEARS.

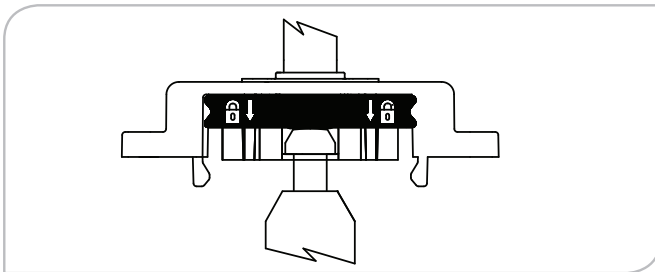

- 4) Unlock stem connector clamp, use fingers on the front and back sides of black lock assembly to evenly raise the lock assembly.

WARNING: WHEN HANDLING THE ACTUATOR TAKE CARE NOT TO DAMAGE THE STEM CONNECTOR CLAMP AND CROSS BAR ASSEMBLY.

- 5) Use actuator manual override to raise the stem connector until the stem adapter is disengaged.

WARNING: DO NOT FORCE OR TURN THE MANUAL OVERRIDE WHEN THE MANUAL OVERRIDE BUTTON IS NOT PRESSED. DOING SO MAY CAUSE DAMAGE TO THE ACTUATOR GEARS.

WARNING: DO NOT LOOSEN THE FACTORY SET ADJUSTABLE HEIGHT SCREWS ON THE SIDES OF THE ACTUATOR YOKE LINKAGE.

- 6) Loosen yoke locknut (item 3) until it is free of bonnet.
- 7) Remove spacer ring (item 2).
- 8) Remove actuator from valve.

WARNING: DO NOT LOOSEN THE FACTORY SET ADJUSTABLE HEIGHT SCREWS ON THE SIDES OF THE ACTUATOR YOKE.

- 9) Hold jam nut (item 4) on valve stem and turn the stem adapter (item 5) to disengage from valve stem.

WARNING: THE VALVE STEM SHOULD NEVER BE TURNED WHILE THE PLUG IS IN CONTACT WITH THE SEAT OTHERWISE THE SEATING SURFACES WILL BE DAMAGED VOIDING THE WARRANTY.

- 10) Remove stem adapter from valve stem.
- 11) Remove jam nut from valve stem.

READ ALL INSTRUCTIONS CAREFULLY BEFORE BEGINNING.

INSTALLATION OF E024 & E025 ACTUATORS ON THE VALVE

SEE DRAWING D3400024 on page 16

THESE INSTRUCTIONS TREAT THE ACTUATOR (ITEM 1) AND LINKAGE BASE (ITEM 17) AS AN ASSEMBLY. FOR INSTRUCTIONS ON HOW TO INSTALL THE ACTUATOR AND THE LINKAGE BASE AS SEPARATE ITEMS SEE THE ADDENDUM ON PAGE 19.

THE SILVER SPACER RING THAT COMES WITH THE ACTUATOR MUST BE ASSEMBLED ON TOP SIDE OF YOKE WITH TURNED DOWN (MACHINED) SIDE FACING DOWN AS SHOWN ON DRAWING.

- 1) Push valve stem down until plug is seated. Note stem location.
- 2) Unlock stem connector clamp, use fingers on the front and back sides of black lock assembly to evenly raise the lock assembly.

WARNING: WHEN HANDLING THE ACTUATOR TAKE CARE NOT TO DAMAGE THE STEM CONNECTOR CLAMP AND CROSS BAR ASSEMBLY.

- 3) Install hex jam nut (Item 4) on valve stem. Thread jam nut so that one inch of threads are exposed between jam nut and top of stem.
- 4) Hold jam nut on valve stem and turn the stem adapter (item 5) until it bottoms out on the valve stem. Tighten jam nut to the bottom of the stem adapter to secure valve stem to stem adapter.

WARNING: THE VALVE STEM SHOULD NEVER BE TURNED WHILE THE PLUG IS IN CONTACT WITH THE SEAT OTHERWISE THE SEATING SURFACES WILL BE DAMAGED VOIDING THE WARRANTY.

- 5) Place actuator, spacer ring (item 2) and yoke locknut (item 3) over valve stem and onto bonnet. Watch orientation of spacer ring and yoke locknut. Actuator base must rest on bonnet. If necessary, use the manual override to raise the stem connector.

WARNING: DO NOT FORCE OR TURN THE MANUAL OVERRIDE WHEN THE MANUAL OVERRIDE BUTTON IS NOT PRESSED. DOING SO MAY CAUSE DAMAGE TO THE ACTUATOR GEARS.

WARNING: DO NOT LOOSEN THE FACTORY SET ADJUSTABLE HEIGHT ADJUSTMENT SCREWS ON THE SIDES OF THE ACTUATOR YOKE LINKAGE.

- 6) Rotate actuator to desired orientation. For the factory default actuator position the motor electrical wire end of the actuator faces the outlet side of a 2-way valve, common "C" port on a 3-way mixing valve, and lower "L" port on a 3-way diverting valve. Thread yoke locknut onto bonnet and tighten securely. Use blunt chisel and hammer for tightening.
- 7) Push valve stem down until plug is seated. Refer to position noted in Step 1.
- 8) Use actuator manual override to lower the stem connector over the stem adapter. Lock stem connector clamp, use fingers on the front and back sides of black lock assembly to evenly lower the lock assembly.

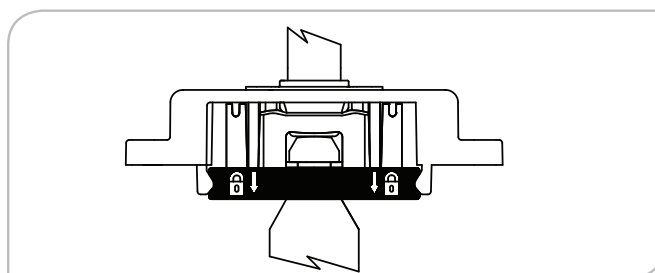

WARNING: DO NOT FORCE OR TURN THE MANUAL OVERRIDE WHEN THE MANUAL OVERRIDE BUTTON IS NOT PRESSED. DOING SO MAY CAUSE DAMAGE TO THE ACTUATOR GEARS.

WARNING: WHEN HANDLING THE ACTUATOR TAKE CARE NOT TO DAMAGE THE STEM CONNECTOR CLAMP AND CROSS BAR ASSEMBLY.

- 9) Push orange travel indicators (item 8) together against both sides of stem connector travel indicator.
- 10) Connect power and signal to actuator. (See also **Set-Up**, page 12)
- 11) Press the Adaption (Auto-Calibration) button on the actuator and wait until the cycle is complete.
- 12) Stroke valve several times to check operation.
- 13) Return line pressure to valve.

READ ALL INSTRUCTIONS CAREFULLY BEFORE BEGINNING.

REMOVAL OF E026 & E029/E030 ACTUATORS FROM VALVE

SEE DRAWING D3400025 on page 17

- 1) Remove line pressure and isolate valve in piping.
- 2) Operate actuator so plug is off seat(s) or travel stop in valve.
- 3) Remove power and signal from actuator. For E026, after power is removed, cycle Fail-Safe Switch from Up Arrow to Down Arrow until actuator stem no longer moves. Adaption/Power (green LED) changes from blinking to off. Return Fail-Safe Switch to original position. If necessary use the manual override to operate actuator so plug is off seat(s) or travel stop in valve.

WARNING: DO NOT FORCE OR TURN THE MANUAL OVERRIDE WHEN THE MANUAL OVERRIDE BUTTON IS NOT PRESSED. DOING SO MAY CAUSE DAMAGE TO THE ACTUATOR GEARS.
- 4) Remove stem connector socket head nuts, remove stem connector U-bolt.
- 5) While carefully manually holding stem connector clamp open on the lower portion, use actuator manual override to raise the stem connector until the stem adapter (item 2) is disengaged.

WARNING: DO NOT FORCE OR TURN THE MANUAL OVERRIDE WHEN THE MANUAL OVERRIDE BUTTON IS NOT PRESSED. DOING SO MAY CAUSE DAMAGE TO THE ACTUATOR GEARS.
- 6) Loosen yoke locknut (item 4) until it is free of bonnet.
- 7) Remove spacer ring (item 3).
- 8) Remove actuator from valve.
- 9) Hold jam nut (item 5) on valve stem and turn the stem adapter to disengage from valve stem.

WARNING: THE VALVE STEM SHOULD NEVER BE TURNED WHILE THE PLUG IS IN CONTACT WITH THE SEAT OTHERWISE THE SEATING SURFACES WILL BE DAMAGED VOIDING THE WARRANTY.
- 10) Remove stem adapter from valve stem.
- 11) Remove jam nut from valve stem.

READ ALL INSTRUCTIONS CAREFULLY BEFORE BEGINNING.

INSTALLATION OF E026 & E029/ E030 ACTUATORS ON THE VALVE

SEE DRAWING D3400025 on page 17

THE SILVER SPACER RING THAT COMES WITH THE ACTUATOR MUST BE ASSEMBLED ON TOP SIDE OF YOKE AS SHOWN ON DRAWING.

- 1) Push valve stem down until plug is seated. Note stem location.
- 2) Remove stem connector socket head nuts, remove stem connector U-bolt.
- 3) Install hex jam nut (Item 5) on valve stem. Thread jam nut so that one inch of threads are exposed between jam nut and top of stem.
- 4) Hold jam nut on valve stem and turn the stem adapter (item 2) until it bottoms out on the valve stem. Tighten jam nut to the bottom of the stem adapter to secure valve stem to stem adapter.

WARNING: THE VALVE STEM SHOULD NEVER BE TURNED WHILE THE PLUG IS IN CONTACT WITH THE SEAT OTHERWISE THE SEATING SURFACES WILL BE DAMAGED VOIDING THE WARRANTY.

- 5) Place actuator, spacer ring (item 3) and yoke locknut (Item 4) over valve stem and onto bonnet. Watch orientation of spacer ring and yoke locknut. Actuator base must rest on bonnet. If necessary, use the manual override to raise the stem connector.

WARNING: DO NOT FORCE OR TURN THE MANUAL OVERRIDE WHEN THE MANUAL OVERRIDE BUTTON IS NOT PRESSED. DOING SO MAY CAUSE DAMAGE TO THE ACTUATOR GEARS.

- 6) Rotate actuator to desired orientation. For the factory default actuator position the motor electrical wire end of the actuator faces the outlet side of a 2-way valve, common "C" port on a 3-way mixing valve, and lower "L" port on a 3-way diverting valve. Thread yoke locknut onto bonnet and tightened securely. Use blunt chisel and hammer for tightening.
- 7) Push valve stem down until plug is seated. Refer to position noted in Step 1.
- 8) While holding the bottom of the stem connector open, use the actuator manual override to lower the stem connector over the stem adapter. Install stem connector U-bolt through stem connector. Watch orientation. The socket head nuts when installed on the U-bolt must face away from the electrical wire end of the motor. Install the socket head nuts on the U-bolt. Evenly torque the socket head nuts to 44 in-lbf torque.

WARNING: DO NOT FORCE OR TURN THE MANUAL OVERRIDE WHEN THE MANUAL OVERRIDE BUTTON IS NOT PRESSED. DOING SO MAY CAUSE DAMAGE TO THE ACTUATOR GEARS.

WARNING: THE VALVE STEM SHOULD NEVER BE TURNED WHILE THE PLUG IS IN CONTACT WITH THE SEAT OTHERWISE THE SEATING SURFACES WILL BE DAMAGED.

- 9) Connect power and signal to actuator. (See also **Set-Up**, page 12)
- 10) Press the Adaption (Auto-Calibration) button on the actuator and wait until the cycle is complete.
- 11) Stroke valve several times to check operation.
- 12) Return line pressure to valve.

SET-UP

Prior to enabling the power perform the following check:

1. Verify the Control Signal. The default Control Signal is 2-10 Vdc (see the wiring diagram for 4-20 mAdc).
2. Review the Control Action by inspecting the Rotation Switch position.
3. Confirm the Power Failure mode by inspecting the Fail-Safe switch.
4. Verify that the actuator is correctly installed on the valve body
5. Enable the Power Source.
6. Perform manual Adaption (Auto-Calibration).

E024, E025, E026, E029 & E030 Actuators - Rotation Switch position. How the valve and actuator react to the Control Signal. The Fail-Safe position during Loss of Power and Loss of Signal are identical for an E024 and E029/E030 with VMS-35.

FACING	DESCRIPTION
Up Arrow (E024 and E029/E030)	Increasing Control Signal Closes, 2-way valves and Lower port for 3-way valve. Signal Failure Direction is Fail Open (FO) 2-way valves and Fail Upper Port Closed for 3-way vales.
Down Arrow (E024 and E029/E030)	Decreasing Control Signal Closes, 2-way valves and Lower Port for 3-way valves. Signal Failure Direction is Failed Closed (FC) for 2-way valves and Fail Lower Port Closed for 3-way valves.
Up Arrow (E024 and E029/E030 w/VMS-35)	Increasing Control Signal Closes, 2-way valves and Lower port for 3-way valve. Signal and Power Failure Direction is Fail Open (FO) 2-way valves and Fail Upper Port Closed for 3-way vales.
Down Arrow (E024 and E029/E030 with VMS-35)	Decreasing Control Signal Closes, 2-way valves and Lower Port for 3-way valves. Signal and Power Failure Direction is Fail Closed (FC) for 2-way valves and Fail Lower Port Closed for 3-way valves.
Up Arrow (E025 & E026)	Increasing Control Signal Closes 2-way valves and Lower Port for 3-way valves. Signal Failure Direction is Fail Open (FO) 2-way valves and Fail Upper Port Closed for 3-way valves.
Down Arrow (E025 & E026)	Decreasing Control Signal Closes 2-way valves and Lower Port for 3-way valves. Signal Failure Direction is Fail Closed (FC) for 2-way valves and Fail Lower Port Closed for 3-way valves.

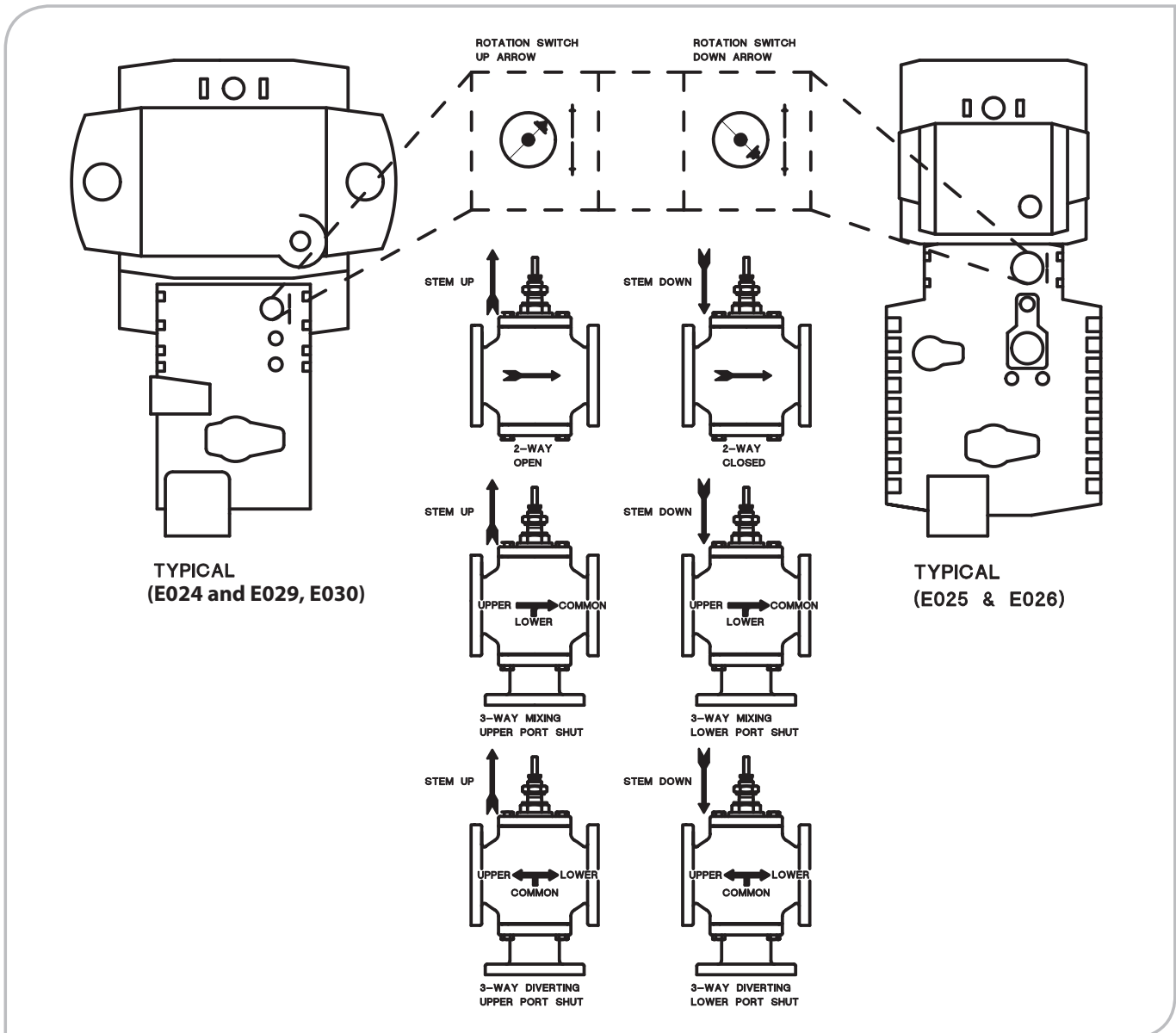

POWER FAILURE

E025 & E026 Actuators - Fail-Safe Switch position: Valve and actuator Power Failure Direction.

FACING	DESCRIPTION
Up Arrow (E025 & E026)	Power Failure Direction is Fail Open (FO) 2-way valves and Upper Port Closed for 3-way valves.
Down Arrow (E025 & E026)	Power Failure Direction is Fail Closed (FC) for 2-way valves and Lower Port Closed for 3-way valves.

Switch must be fully in position shown or actuator will go to intermediate position on loss of power.

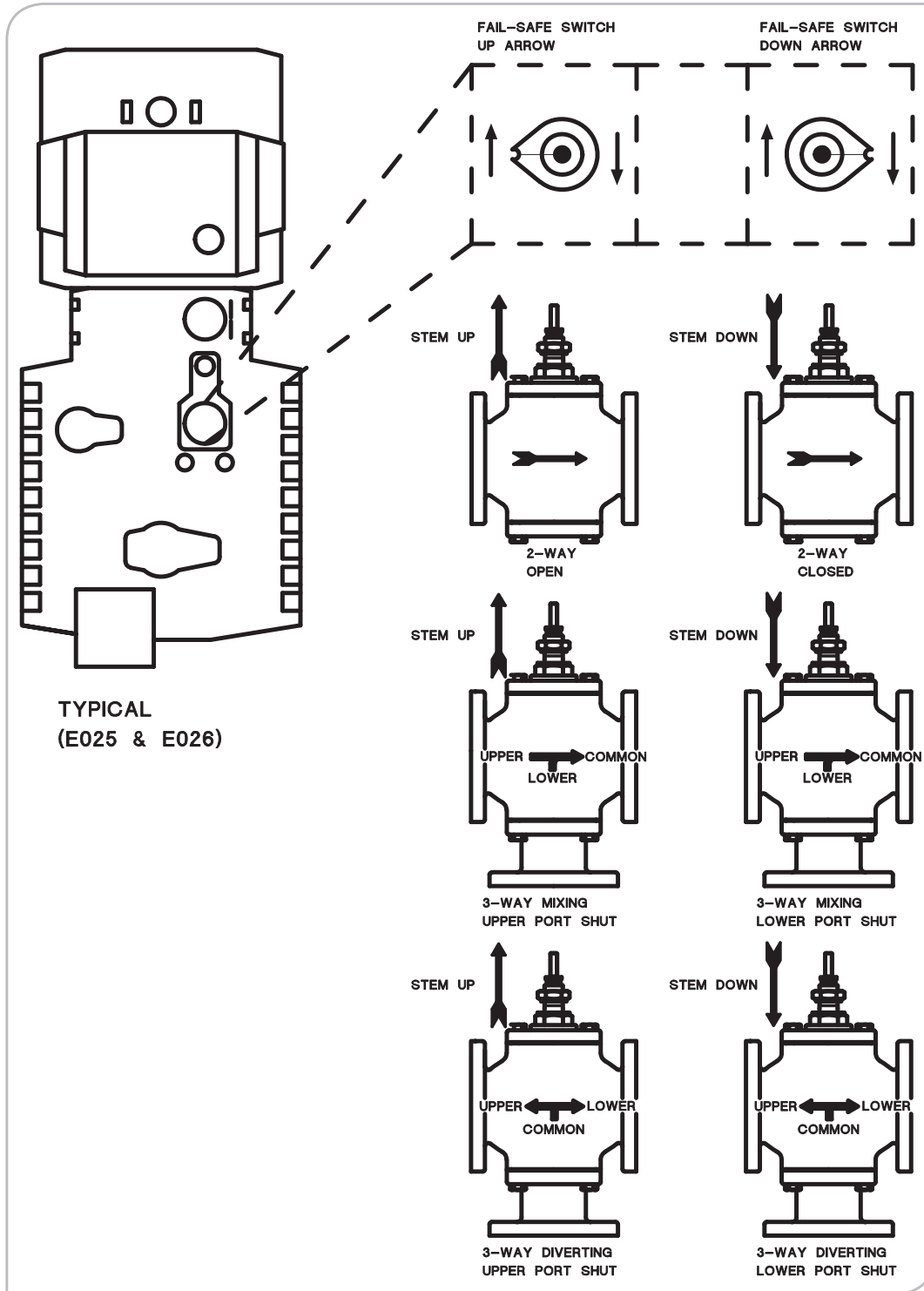

STATUS (yellow LED)	ADAPTION/ POWER (green LED)	DESCRIPTION
OFF	ILLUMINATED	Normal (no faults)
OFF	BLINKING	Power Failure is active (E025 & E026 only)
ILLUMINATED	OFF	Fault is detected ¹
OFF	OFF	No Power or Capacitors charging
ILLUMINATED	ILLUMINATED	Auto-Calibration is running

NOTE:

- 1) Verify Control and Feedback Wiring and Signals if a Fault is detected.

D3400024

THIS DRAWING IS THE PROPERTY OF TRETRICE INC. AND IS NOT TO BE REPRODUCED, COPIED, REPRODUCED, TRANSMITTED, OR OTHERWISE DISCLOSED TO ANY OTHER PARTY WITHOUT THE WRITTEN CONSENT OF TRETRICE INC. ANY UNAUTHORIZED REPRODUCTION OR USE OF THIS DRAWING IS STRICTLY PROHIBITED. TRETRICE INC. 12750 W. EIGHT MILE RD., OAK PARK, MI 48237

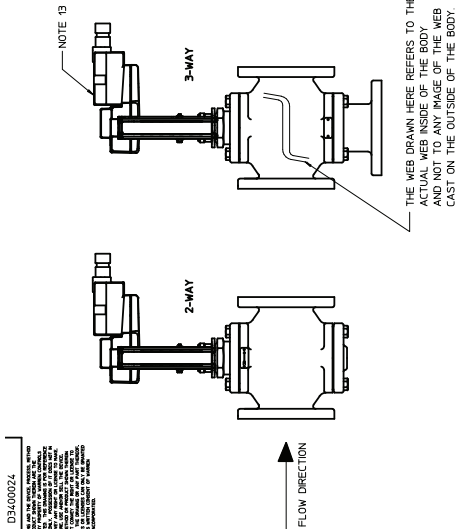

REV	DESCRIPTION	DATE	APPROVED
A	REDRAWN WITH CHANGES ECN 2750	01-30-14	DGS

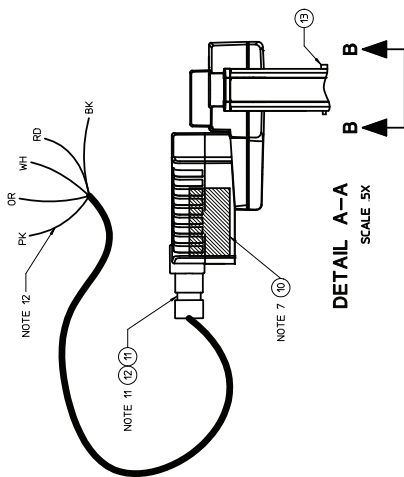
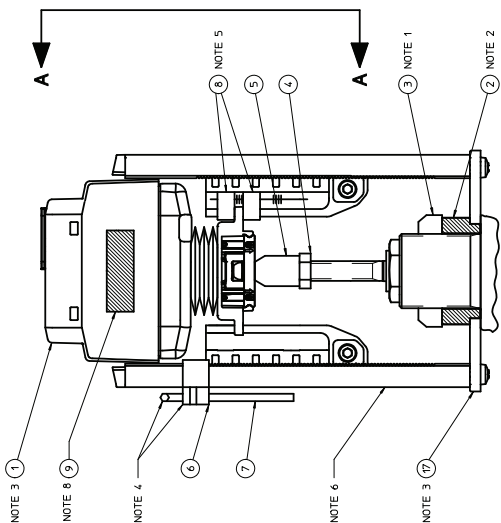

ITEM	QTY	PART NO	DESCRIPTION	MATL. SPEC
17	1		LINKAGE BASE WITH TRACKS	
16	2		LINKAGE NUT THREADED	
15	4		SPRINGS	
14	2		FRONT LINKAGE LOCK NUT	
13	2		SOCKET HEAD CAP SCREW 4mm	
12	A/R	PUR1232	WIRE TIE	
11	1	KR500	RESISTOR KIT	
10	1		SERIAL TAG	
9	1	B1670075	DOME TAG	
8	1		TWO (2) ORANGE TRAVEL INDICATORS	
7	1		4 MM ALLEN KEY	
6	1		KEY CLIP	
5	1		STEM ADAPTER	
4	1		3/8-24 JANNUIT	
3	1		YOKE LOCKNUT (SAME AS B440034-01)	
2	1		SPACER RING	
1	1		LINEAR ELECTRONIC ACTUATOR WITH RAILS	

REV	QTY	PART NO	DESCRIPTION	MATL. SPEC

- 1) THE MOTOR ELECTRICAL WIRE END OF THE ACTUATOR FACES THE OUTLET SIDE OF A 2-WAY VALVE, C PORT ON A 3-WAY MIXING AND L PORT ON A 3-WAY DIVERTER VALVE
- 2) PUR1232 ONLY: CUT END OF FIFTH PINK WIRE DOWN TO JACKET INSULATION
- 3) THREAD APPROXIMATELY 1/8 IN OF WIRE TIE THROUGH RESISTOR KIT BAG HOLE AND ATTACH TO NARROW DIAMETER AS SHOWN
- 4) ALL PARTS EXCEPT ITEMS 9, 10, 11 AND 12 ARE INCLUDED IN PURCHASED KIT PUR1234 OR PUR1235
- 5) SEE WORK INSTRUCTION W100036 FOR DETAILS
- 6) CENTER DOME TAG AS SHOWN
- 7) LOCATE SERIAL TAG ON LOWER LEFT CORNER AS SHOWN
- 8) WITH ACTUATOR IN STEM UP POSITION, SLIDE LINKAGE BASE ONTO ACTUATOR LINKAGE LEGS. ADJUST LINKAGE HEIGHT TO THE NEXT TOOTH ABOVE LINKAGE GAGE B6020013. TORQUE SOCKET HEAD CAP SCREWS TO 44 IN-LB-F.
- 9) AFTER THE ACTUATOR IS MOUNTED, AND BEFORE IT IS SET UP AND TESTED, THE ORANGE TRAVEL INDICATORS SHALL BE PUSHED TO CONTACT THE TRAVEL INDICATOR CROSS BAR.
- 10) ATTACH CLIP AND ALLEN KEY AS SHOWN
- 11) VBA MUST MEET NS INTERFACE. B3760073
- 12) THE NICKEL PLATED SPACER RING (AKKVA COLLARI) INCLUDED WITH THE ACTUATOR MUST BE PUSHED DOWN THE HOLE IN THE LINKAGE BASE AS SHOWN. THE TURNED DOWN SIDE FACING THE HOLE IN THE LINKAGE BASE AS SHOWN.
- 13) YOKE LOCKNUT MUST BE ORIENTED WITH THE FLAT SIDE DOWN AS SHOWN.

NOTES

18001

03847

D3400024

REV

A

REV	DESCRIPTION	DATE	BY
C	REDRAWN WITH CHANGES ECN 2764	4-3-14	DGS

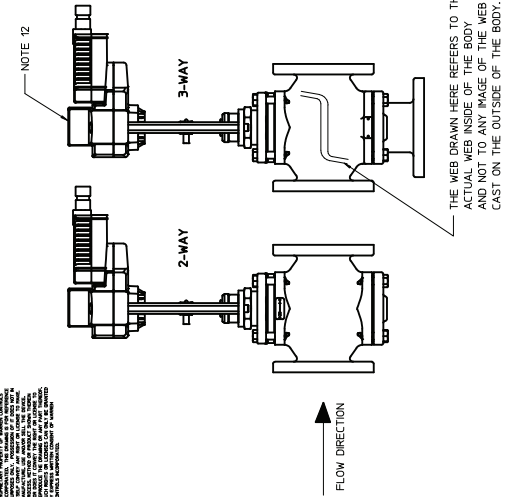

THE WEB DRAWN HERE REFERS TO THE ANGLE BRACKET ON THE INSIDE OF THE WEB AND NOT TO ANY BRACE OF THE WEB CAST ON THE OUTSIDE OF THE BODY.

DEFAULT ACTUATOR ORIENTATION

NO SCALE

- 13) TORQUE SOCKET HEAD CAP SCREWS TO 177 IN-LBS TO SECURE ACTUATOR (ITEM 1) TO EACH LEG OF LINKAGE BASE (ITEM 14) IN 2 PLACES THROUGH ACTUATOR RECESS AS SHOWN.
- 12) THE MOTOR ELECTRICAL WIRE END OF THE ACTUATOR FACES THE OUTLET SIDE OF A 2-WAY VALVE, C PORT ON A 3-WAY MIXING AND L PORT ON A 3-WAY DIVERTER VALVE.
- 11) THREAD, APPROXIMATELY .6 IN OF WIRE TIE THROUGH RESISTOR KIT BAG HOLE AND ATTACH TO NARROW DIAMETER WHERE SHOWN.
- 10) SEE WORK INSTRUCTION W100017 FOR DETAILS.
- 9) TORQUE 5MM HEX SOCKET TO 44 IN-LBF.
- 8) CENTER DOME TAG AS SHOWN.
- 7) LOCATE SERIAL TAG ON LOWER LEFT CORNER AS SHOWN.
- 6) ATTACH TRAVEL SCALE LABEL AS SHOWN.
- 5) ALL PARTS EXCEPT ITEMS 2, 8, 9, 10, 11 AND 12 ARE INCLUDED IN PURCHASE KIT PUR1232 OR PUR1237.
- 4) ATTACH CLIP AND ALLEN KEY AS SHOWN.
- 3) VBA MUST MEET NS INTERFACE, B3760073.
- 2) THE NICKEL PLATED SPACER RING (AK/A COLLARI) INCLUDED WITH THE ACTUATOR LINKAGE KIT (WVLU) INSTALLED FROM ABOVE.
- 1) YOKE LOCKNUT MUST BE ORIENTED WITH THE FLAT SIDE FACING DOWN AS SHOWN.

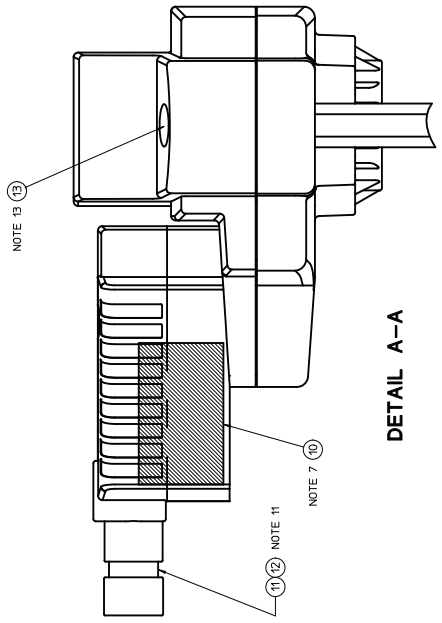
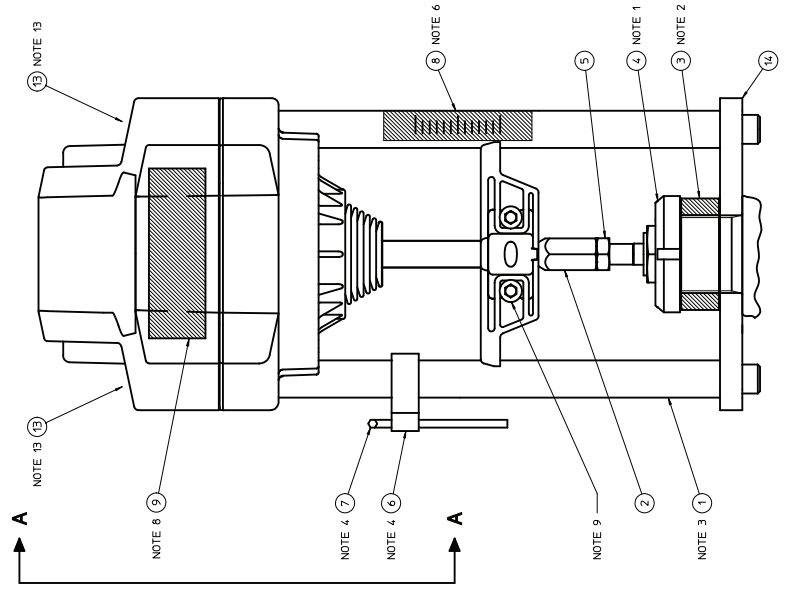

14	1	LINKAGE BASE							
13	2	SOCKET HEAD CAP SCREW 6mm							
12	A/R	PUR1232							
11	1	RESISTOR KIT							
10	1	SR500							
9	1	SEE TABLE							
8	1	TRAVEL SCALE LABEL							
7	1	5 MM ALLEN KEY							
6	1	KEY CLIP							
5	1	3/8-24 JAMNUT							
4	1	YOKE LOCKNUT (SAME AS B3640034-01)							
3	1	SPACER RING							
2	1	C1010075-01							
1	1	PER 8/A							

1 1/2 MOVE ALL	B1590066								
1 3/8 MOVE ALL	B1590065								
1 1/4 MOVE ALL	B1590064								
1 1/8 MOVE ALL	B1590063								
3/4 MOVE ALL	B1590062								
VBA USED ON	B1590067								

REV	DATE	BY
D	03647	10012
PART FULL		
D3400025		

NOTES:

READ ALL INSTRUCTIONS CAREFULLY BEFORE BEGINNING.

REMOVAL OF E024 & E025 ACTUATOR AND LINKAGE BASE FROM VALVE

SEE DRAWING D3400024 on page 16

THESE INSTRUCTIONS SHOULD ONLY BE USED IF THE SOCKET HEAD CAP SCREWS (ITEM 13) HAVE BEEN LOOSENED AND THE POSITION OF THE ACTUATOR (ITEM 1) RELATIVE TO THE LINKAGE BASE (ITEM 17) HAS BEEN CHANGED. OTHERWISE USE THE REMOVAL AND INSTALLATION INSTRUCTIONS ON PAGE 8 & 9.

- 1) Remove line pressure and isolate valve in piping.
- 2) Operate actuator (item 1) so plug is off seat(s) or travel stop in valve.
- 3) Remove power and signal from actuator. For E025, after power is removed, cycle Fail-Safe Switch from Up Arrow to Down Arrow until actuator stem no longer moves. Adaption/Power (green LED) changes from blinking to off. Return Fail-Safe Switch to original position. If necessary use the manual override to operate actuator so plug is off seat(s) or travel stop in valve.

WARNING: DO NOT FORCE OR TURN THE MANUAL OVERRIDE WHEN THE MANUAL OVERRIDE BUTTON IS NOT PRESSED. DOING SO MAY CAUSE DAMAGE TO THE ACTUATOR GEARS.

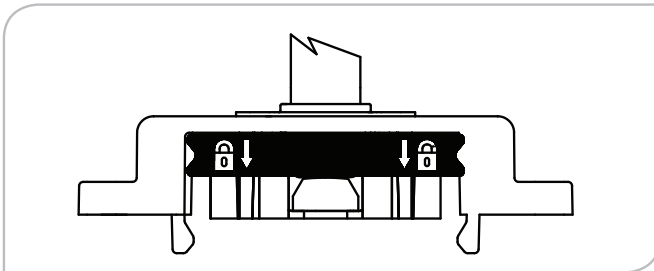

- 4) Unlock stem connector clamp, use fingers on the front and back sides of black lock assembly to evenly raise the lock assembly.

WARNING: WHEN HANDLING THE ACTUATOR TAKE CARE NOT TO DAMAGE THE STEM CONNECTOR CLAMP AND CROSS BAR ASSEMBLY.

- 5) Press the manual override button then use the actuator manual override to raise the stem connector until the stem adapter (item 5) is disengaged.

WARNING: DO NOT FORCE OR TURN THE MANUAL OVERRIDE WHEN THE MANUAL OVERRIDE BUTTON IS NOT PRESSED. DOING SO MAY CAUSE DAMAGE TO THE ACTUATOR GEARS.

- 6) Adjust the socket head cap screws (item 13) so the teeth of the front linkage lock nuts (item 14) will not interfere with the teeth of linkage base tracks (item 17).

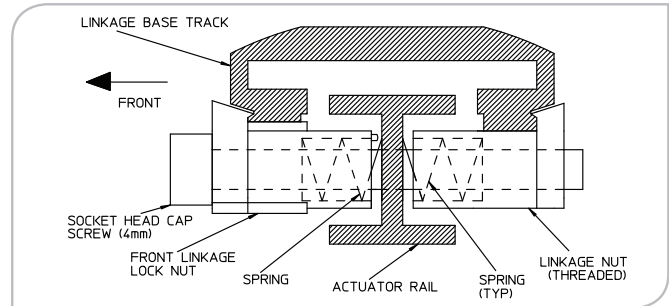

- 7) Press together the linkage base tracks and slide the actuator rails out of the tracks until the actuator is separate from the linkage base.
- 8) Thread the socket head cap screws out of the threaded linkage nuts (item 16). Remove and separate the threaded linkage nuts and springs (item 15).
- 9) Remove the socket head cap screws, front linkage lock nuts, and springs together from the actuator rails. Separate the socket head cap screws, front linkage nuts, and springs.
- 10) Remove the orange travel indicators (item 8) from the actuator rail.
- 11) Loosen yoke locknut (item 3) until it is free of bonnet.
- 12) Remove spacer ring (item 2).
- 13) Remove linkage base from valve.
- 14) Hold jam nut (item 4) on valve stem and turn the stem adapter (item 5) to disengage from valve stem.

WARNING: THE VALVE STEM SHOULD NEVER BE TURNED WHILE THE PLUG IS IN CONTACT WITH THE SEAT OTHERWISE THE SEATING SURFACES WILL BE DAMAGED VOIDING THE WARRANTY.

- 15) Remove stem adapter from valve stem.
- 16) Remove jam nut from valve stem.

READ ALL INSTRUCTIONS CAREFULLY BEFORE BEGINNING.

INSTALLATION OF E024 & E025 ACTUATOR AND LINKAGE BASE ON A VALVE

SEE DRAWING D340024 on page 16

THESE INSTRUCTIONS SHOULD ONLY BE USED IF THE SOCKET HEAD CAP SCREWS (ITEM 13) HAVE BEEN LOOSENED AND THE POSITION OF THE ACTUATOR (ITEM 1) RELATIVE TO THE LINKAGE BASE (ITEM 17) HAS BEEN CHANGED. OTHERWISE USE THE REMOVAL AND INSTALLATION INSTRUCTIONS ON PAGE 8 & 9.

THE SILVER SPACER RING THAT COMES WITH THE ACTUATOR MUST BE ASSEMBLED ON TOP SIDE OF YOKE WITH TURNED DOWN (MACHINED) SIDE FACING DOWN AS SHOWN ON DRAWING D340024.

- 1) Push valve stem down until plug is seated. Note stem location.
- 2) Install hex jamnut (Item 4) on valve stem. Thread jamnut so that one inch of threads are exposed between jamnut and top of stem.
- 3) Hold jamnut on valve stem and turn the stem adapter (item 5) until it bottoms out on the valve stem. Tighten jamnut to the bottom of the stem adapter to secure valve stem to stem adapter.

WARNING: THE VALVE STEM SHOULD NEVER BE TURNED WHILE THE PLUG IS IN CONTACT WITH THE SEAT OTHERWISE THE SEATING SURFACES WILL BE DAMAGED VOIDING THE WARRANTY.

- 4) Place linkage base (item 17), spacer ring (item 2), and yoke locknut (item 3) over valve stem and onto bonnet. Watch orientation of spacer ring and yoke locknut. Linkage base must rest on bonnet.
- 5) Rotate linkage base to desired orientation. For the factory default actuator position, when the actuator (item 1) is installed in the linkage base, the motor electrical wire end of the actuator faces the outlet side of a 2-way valve, common "C" port on a 3-way mixing, and lower "L" port on a 3-way diverting valve. Thread yoke locknut onto bonnet and tighten securely. Use a blunt chisel and hammer for final tightening.
- 6) Unlock stem connector clamp on the actuator, use fingers on the front and back sides of black lock assembly to evenly raise the lock assembly.

WARNING: WHEN HANDLING THE ACTUATOR TAKE CARE NOT TO DAMAGE THE STEM CONNECTOR CLAMP AND CROSS BAR ASSEMBLY.

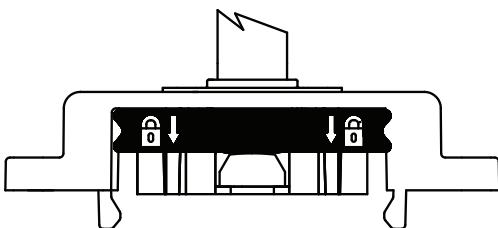

- 7) Press the manual override button then use the actuator manual override to lower the stem connector until a slight resistance is felt. Then raise the stem connector approximately 2-1/4 turns of the manual override (approximately 0.086 inch).

WARNING: DO NOT FORCE OR TURN THE MANUAL OVERRIDE WHEN THE MANUAL OVERRIDE BUTTON IS NOT PRESSED. DOING SO MAY CAUSE DAMAGE TO THE ACTUATOR GEARS.

- 8) Insert first socket head cap screw (item 13) through front linkage lock nut (item 14). Watch orientation. Install first spring (item 15) over threaded end of socket head cap screw into spring bore of front linkage lock nut. Insert threaded end of socket head cap screw into hole in socket for front linkage lock nut in one of the actuator rails. The socket for the front linkage lock nut is oriented away from the motor electrical wire end of the actuator. Press front linkage lock nut into socket. The teeth on the front linkage lock nut must face the teeth on the closest linkage base track when the actuator is installed on the linkage base. Install second spring on exposed threaded end of the socket head cap screw. Install threaded linkage nut (item 16) over threaded end of socket head cap screw so second spring is captured in spring bore of threaded linkage nut. The dovetail on the threaded linkage nut must face the groove in the closest linkage base track when the actuator is installed on the linkage base. Thread the socket head cap screw into the threaded linkage nut. Adjust the socket head cap screw so the teeth of the front linkage lock nut will not interfere with the teeth of linkage base track when the actuator is installed in the linkage base in the next step. Repeat this step with second socket head cap screw
- 9) Verify the valve stem is down and the plug is seated. Refer to location noted in Step 1. Position the actuator (item 1) in the desired orientation. For the factory default actuator position, the motor electrical wire end of the actuator faces the outlet side of a 2-way valve, common "C" port on a 3-way mixing valve, and lower "L" port on a 3-way diverting valve. Verify that the teeth of both front linkage lock nuts will face the teeth in the closest linkage base track when the actuator is installed in the linkage base. Verify that the dovetail of both threaded linkage nuts will face the groove in the closest linkage base track when the actuator is installed in the linkage base. Press together the linkage base tracks and insert the actuator rails into the tracks. Slide the actuator rails into the actuator base tracks until the metal actuator stem touches the top of the stem adapter.

READ ALL INSTRUCTIONS CAREFULLY BEFORE BEGINNING.

INSTALLATION OF E024 & E025 ACTUATOR AND LINKAGE BASE ON A VALVE CONTINUED

10) Press the first threaded linkage nut into the socket on the actuator rail and hold. The dovetail on the threaded linkage nut must fully engage the groove on the linkage base track. Press the front linkage lock nut into the socket on the actuator rail and hold. The teeth on the front linkage lock nut must engage the lowest teeth possible on the linkage base track. The dovetail on the front linkage lock nut must fully engage the groove on the linkage base track. Tighten the socket head cap screw hand tight. Repeat for the second threaded linkage nut. The number of teeth visible on the linkage base tracks below the front linkage lock nuts should be the same on both sides. If the number of teeth visible on the linkage base tracks below the front linkage lock nuts is not the same on both sides, loosen the socket head cap screws then repeat this step.

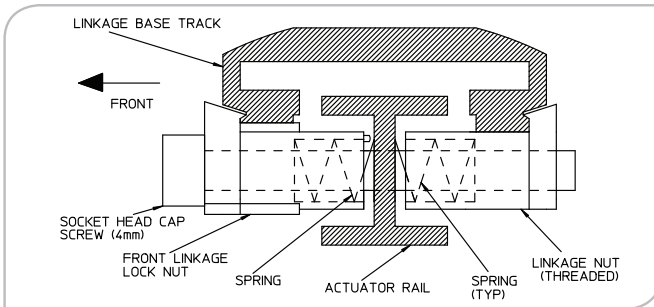

- 11) Tighten both 4 mm socket head cap screws to 44 in-lbf torque.
- 12) Use actuator manual override to verify the metal actuator stem touches the top of the stem adapter.

WARNING: DO NOT FORCE OR TURN THE MANUAL OVERRIDE WHEN THE MANUAL OVERRIDE BUTTON IS NOT PRESSED. DOING SO MAY CAUSE DAMAGE TO THE ACTUATOR GEARS.

13) Lock stem connector clamp, use fingers on the front and back sides of black lock assembly to evenly lower the lock assembly.

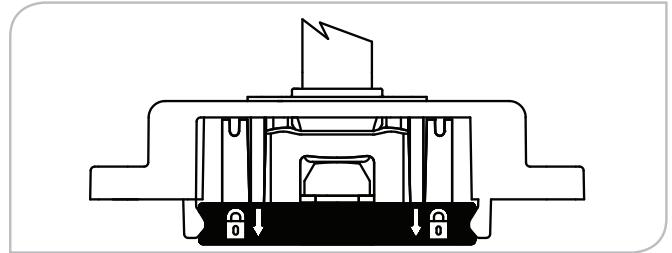

WARNING: WHEN HANDLING THE ACTUATOR TAKE CARE NOT TO DAMAGE THE STEM CONNECTOR CLAMP AND CROSS BAR ASSEMBLY.

- 14) Install orange travel indicators (item 8) on embossed actuator rail above and below travel indicator cross bar. Push orange travel indicators on leg of actuator to contact cross bar.
- 15) Connect power and signal to actuator. (See also **Set-Up** on page 12)
- 16) Press the Adaption (Auto Calibration) button on the actuator and wait until the cycle is complete.
- 17) Stroke valve several times to check operation.
- 18) Return line pressure to valve.

NOTES

NOTES

NOTES



Manufacturer of:

Pressure Gauges • Temperature Instrumentation • Regulators & Control Valves

TRERICE Corporate Headquarters
Customer Service and International Sales
12950 W. Eight Mile Road, Oak Park, Michigan 48237

Toll Free: 1-888-873-7423

Fax: 1-248-399-7246

www.TRERICE.com

sales@trerice.com