

Operation, Installation & Maintenance Manual

Series 91000 Self-Operating Temperature Regulators



Model 91400 Shown

Indicating and Non-indicating



Operation, Installation & Maintenance Manual

TABLE OF CONTENTS

Principles of Operation of the Regulator	3
Identifying Your Unit	
Pressure and Temperature Limits	4
Regulator – Installation	5
Sensing Bulb – Location & Installation	6
Placing Regulator into Operation & Setting Control Point	7
Routine Service	8
Stem Seal Packing	9
Checking the Regulator for Proper Action	10-11
Valve Body Assembly	12-13
Reversing the Valve Action	14-15
3-Way Regulator – Installation & Maintenance	16
Model 91600 – “Safety-Type” Installation & Maintenance	17
Typical Applications	18-19
Typical Heat Exchanger Application Using a Self-Op 2-Way Valve	
Typical Heat Exchanger Application Using a Self-Op 3-Way Diverting Valve	
Typical Plumbing for a Self-Op 3-Way Mixing Valve	
Typical Water Application Using a Self-Operating Regulator	
Typical Fuel Storage Application Using a Self-Operating Regulator	
Typical Plating or Pickling Application Using a Self-Operating Regulator	
Trouble-Shooting	20-21

PRINCIPLES OF OPERATION OF THE REGULATOR

The Trerice **Series 91000** Temperature Regulator operates on the vapor pressure principle. The thermally sensitive bulb of the instrument contains a fluid that creates a vapor which increases or decreases in pressure as the sensing bulb temperature increases or decreases. This vapor pressure is transmitted hydraulically to the bellows which, opposed by the adjusting (return) spring, actuates the valve controlling the flow in proportion to the sensed temperature at the bulb. Raising or lowering the adjusting screw will change the compression of the spring against the bellows, thus raising or lowering the control temperature. For the most sensitive operation a nominal range should be selected that contains the desired control point in the upper 1/3 of the nominal range. The vapor pressure response is greater per unit of temperature change in the upper portion of the nominal range. All TRERICE temperature regulators (with the exception of the 91600 "Safety-Type") are equipped with an over-range feature which allows the bulb to be heated 100°F above the nominal range without damaging the temperature sensing system.

IDENTIFYING YOUR UNIT – 91000 & 91400 Actuators

Range Code	Nominal Range	Recommended Working Span		Dial Thermometer Range (Model 91400 only)
		Single Seat, In-To-Close Valves Double Seat, In-To-Close Valves Double Seat, In-To-Open Valves All 3-Way Valves	Single Seat In-To-Open Valves	
R01*	20° to 70°F & -10° to 20°C	40° to 65°F & 5° to 20°C	N/A	30° to 115°F & C
R02*	40° to 90°F & 5° to 30°C	65° to 85°F & 20° to 30°C	N/A	50° to 140°F & C
R03	30° to 115°F & 0° to 45°C	85° to 110°F & 30° to 45°C	50° to 80°F & 10° to 25°C	30° to 115°F & C
R04	50° to 140°F & 10° to 60°C	110° to 135°F & 45° to 60°C	80° to 105°F & 25° to 45°C	50° to 140°F & C
R05	75° to 165°F & 25° to 70°C	135° to 160°F & 60° to 70°C	105° to 130°F & 40° to 50°C	75° to 165°F & C
R06	105° to 195°F & 40° to 90°C	160° to 190°F & 70° to 90°C	130° to 155°F & 50° to 65°C	105° to 195°F & C
R07	125° to 215°F & 55° to 100°C	190° to 210°F & 90° to 100°C	155° to 180°F & 65° to 80°C	125° to 215°F & C
R09	155° to 250°F & 70° to 120°C	210° to 245°F & 100° to 120°C	180° to 215°F & 80° to 100°C	155° to 250°F & C
R10	200° to 280°F & 95° to 135°C	245° to 275°F & 120° to 135°C	215° to 245°F & 100° to 120°C	200° to 280°F & C
R11	225° to 315°F & 110° to 155°C	275° to 310°F & 135° to 155°C	245° to 280°F & 120° to 140°C	225° to 315°F & C
R12	255° to 370°F & 125° to 185°C	305° to 365°F & 155° to 185°C	275° to 335°F & 135° to 165°C	255° to 370°F & C
R13	295° to 420°F & 145° to 215°C	365° to 415°F & 185° to 215°C	335° to 385°F & 165° to 195°C	295° to 420°F & C
R14	310° to 440°F & 155° to 225°C	415° to 435°F & 215° to 225°C	385° to 405°F & 195° to 205°C	310° to 440°F & C

*Not recommended for single seated valves.

STANDARD RANGES 91600 Safety-Type Actuators

Range Code	Nominal Range and Recommended Working Span
R81	40° to 65°F & 5° to 20°C
R82	55° to 80°F & 15° to 25°C
R83	65° to 90°F & 20° to 30°C
R84	80° to 110°F & 25° to 40°C
R85	90° to 115°F & 30° to 45°C
R86	110° to 140°F & 40° to 60°C
R89	140° to 175°F & 60° to 80°C
R90	170° to 195°F & 80° to 90°C
R91	190° to 210°F & 85° to 100°C
R92	205° to 225°F & 95° to 105°C
R93	215° to 250°F & 100° to 120°C
R94	230° to 265°F & 110° to 130°C
R95	245° to 280°F & 120° to 135°C
R96	270° to 300°F & 135° to 150°C

PRESSURE AND TEMPERATURE LIMITS

Maximum Static Pressure

Valve bodies in 1/2" through 2" sizes are rated for 250 PSIG max.

Valve bodies in 2 1/2" through 6" sizes are rated for 125 PSIG max.

Maximum Pressure Drop through the Valve

The "Pressure Drop" is the change in pressure of the process fluid as it passes through the valve.

A self-operating temperature regulator is often used on installations that at times will require a full shut off, causing the pressure drop to equal the total inlet pressure. Therefore the inlet pressure should not exceed the maximum pressure drops as listed in the following table.

MAXIMUM PSI DROP THRU VALVE				
Models 91000 & 91400				Model 91600
Valve	Single Seated	Double Seated	3-Way Sleeve Type	Safety Type
1/2"	250	–	250	100
3/4"	140	250	250	250
1"	80	250	250	250
1 1/4"	50	250	250	175
1 1/2"	35	250	250	150
2"	20	250	250	100
2 1/2"	–	65	125	–
3"	–	50	125	–
4"	–	40	125	–
5"	–	30	–	–
6"	–	25	–	–

Maximum Valve Body (Process Fluid) Temperatures

Two-way plug type valves 1/2" through 2" are rated for 410°F.

Two-way plug type valves 2 1/2" through 6" bodies are rated to 350°F.

Three-way sleeve type valves (all sizes) are rated to 300°F.

Pressure Limits for Temperature Sensing Bulbs

The temperature sensing bulbs on a regulator are not recommended for direct insertion into any pressurized system. The use of a Thermowell is strongly encouraged.

Brass and Steel Thermowells are rated to 500 PSIG.

Stainless Steel Thermowells are rated to 1000 PSIG.

INSTALLATION

Deciding the LOCATION for the Regulator

The regulator should be installed in an accessible location on horizontal piping. Possible damage from moving parts, splashing of corrosive liquids, vibration, heat, fluid pulsations, etc., should be considered in deciding the location. Similar consideration should also be given to the connecting tubing and bulb. The tubing for the special purpose "Small Bulb" option (9" long) should be located where the temperature is at least 20°F cooler than the control point.

REGULATOR Installation

A strainer should be installed just ahead of the regulator to protect the valve from dirt, scale or foreign matter which could interfere with the seating of the valve. A three valve by-pass installed around the regulator will facilitate removal for service.

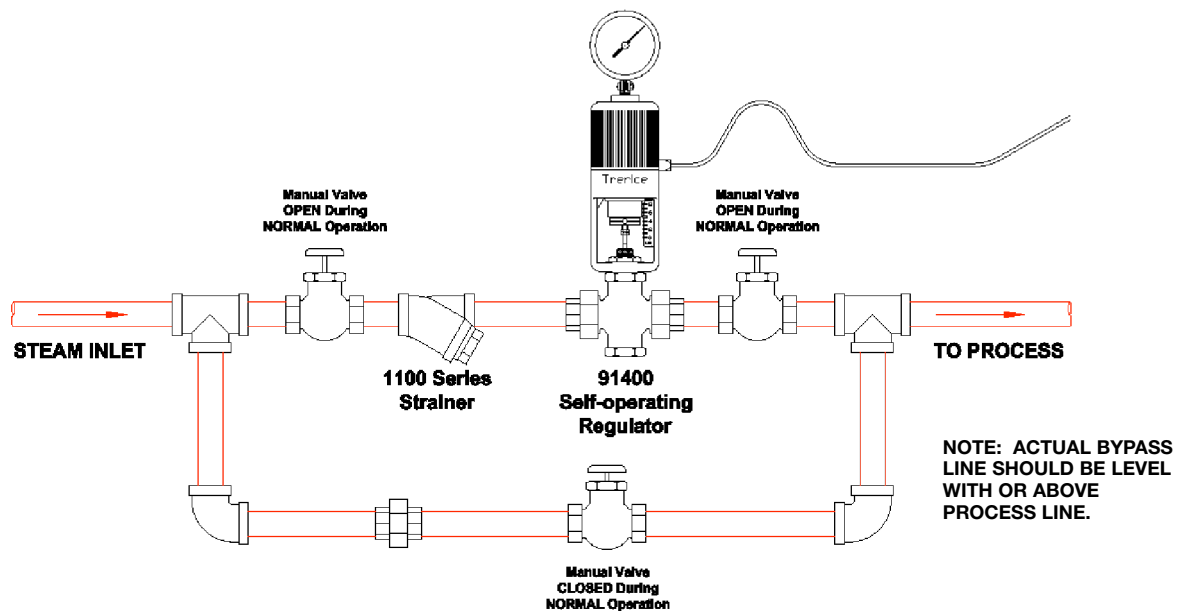

Blow out all pipe lines thoroughly to eliminate all foreign material from the system. Pipe thread compound should be applied only on external or male pipe threads (not on the union nut threads). Install the regulator in a vertical position with the flow direction through the valve corresponding to the flow arrow cast on the valve body. Tighten tailpieces of unions on piping first and then tighten both valve union nuts simultaneously.

Positioning the Indicator

The Model 91400 Self-Operating Regulator contains an integral dial thermometer that can be rotated 330° about the vertical axis for best readability. To prevent thermal system damage, a rotation stop is built in. If the stop prevents a proper viewing angle from being achieved, rotate the thermometer in the opposite direction. This thermometer can also be tilted up or down for maximum readability. To tilt, loosen the clevis screw/nut, tilt thermometer to desired angle and re-tighten the clevis screw/nut combination.

SENSING BULB

SENSING BULB LOCATION

The location of the sensing bulb is important. **Use of a thermowell is always recommended, especially in pressurized systems.** The bulb or thermowell must be totally immersed in an average temperature location which is representative of the whole volume being controlled. It should not be situated near hot or cold spots, nor near the outlet of the valve supplying the heated or chilled fluid. If the regulator is to control a corrosive fluid the bulb or thermowell must be constructed of a compatible material. Never install the bulb with the dead end up unless it has been specifically ordered from, and constructed by, the factory for this service.

When installed in a pipeline, continuous flow past the sensing bulb must be maintained to obtain continuous temperature signal to the regulator. If the flow stops, the pipeline may cool or warm to local room temperature causing false reactions from the regulating valve. On some systems this may require a small by-pass flow line around the valve to maintain representative system temperatures at the sensing bulb.

SENSING BULB INSTALLATION

To install a union connected sensing bulb, remove the union hub or thermowell from the sensing bulb and install this hub or thermowell into the process piping or tank. If using a thermowell, liberally coat the sensing bulb with the heat transfer paste supplied with the thermowell. Now slip the sensing bulb through the hub or into the well until fully seated. Tighten the coupling nut. Do not over tighten.

Never attempt to tighten, loosen or otherwise rotate the hub or thermowell with the sensing bulb installed. Always loosen the coupling nut before rotating the hub or thermowell. This will prevent twisting and kinking of the connecting tubing thus preventing premature failure.

Keep all bends in the tubing greater than 1 1/2" radius. Do not subject the tubing to repeated flexing, vibration, heat, cutting, kinking or other abuse. Coil all excess tubing and place in a cool location. If motion or vibration may occur, secure the tubing to the bulb mounting so all moves as one. If vibration or fluid pulsations may be transmitted to the bulb, it must be housed in a thermowell for protection from fatigue.

PLACING THE REGULATOR INTO OPERATION AND SETTING THE CONTROL POINT

Using the supplied 1/4" rod, turn the 1 3/4" adjusting screw to a position on the "0 to 8" reference scale to a position that approximately corresponds to the relative position of the desired control point within the adjustable range. The "V" slot in the adjusting screw is intended as the index line for recording the setting number in maintenance logs. To raise the control point, turn the adjusting screw from left to right up toward "HIGH" marked on the reference scale. To lower the control point, turn the adjusting screw from right to left down toward "LOW" marked on the reference scale. **This adjustment must be done at system operating pressure to balance the stem thrust load for proper regulation.**

**DO NOT TURN THE SMALL HEX STEM JAM NUTS.
THIS IS A CRITICAL SETTING FOR THE PROPER SEATING & STROKE OF THE REGULATOR.**

**CAUTION:
DO NOT TURN THE ADJUSTING
SCREW BELOW THE "0" MARK**

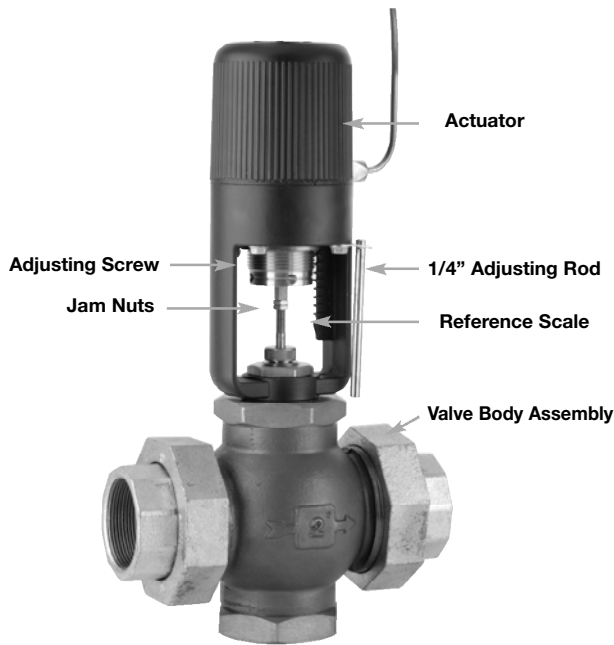

Figure 1: (Model 91000 shown)

When the downstream units are ready to receive flow, close the by-pass valve and open all upstream supply valves slowly to allow gradual start-up.

Observe the controlled temperature after it stabilizes and re-adjust the adjusting screw as required to obtain the desired control point. Initial over shooting may occur until the system approaches equilibrium. Allow sufficient time for correction to take place after each adjustment before further changing the setting.

Be certain that all manual valves in the main flow line are fully open and not restricting the flow. Also be sure all downstream units are passing the flow properly.

ROUTINE SERVICE

Since this instrument is self-contained and practically trouble free, very little maintenance is required. It is important to keep the stem clean and free of deposits where it passes through the stem seals at the bonnet. An occasional drop of oil on the stem will aid in eliminating mineral deposits and maintaining a free running stem for accurate regulation. See Figure.



Figure 2

Removing any sharp mineral crystals from the stem will also reduce the chance of cutting the seal lips and will prolong the seal life.

The packing seal is self-adjusting.

Do Not Tighten the packing nut beyond finger tight.

Leakage should never be tolerated. Any leak at bonnets, unions, plugs, etc., requires immediate correction to avoid erosive action and serious damage or personal injury.

STEM SEAL PACKING

The regulator uses Teflon “V” ring packing sets with stainless steel male and female adapters used as end rings, with a stainless steel compression spring. This spring loading of the packing maintains proper compression of the rings and also compensates for wear that occurs at the seals. No adjustment is need and the packing nut should always be threaded all the way onto the bonnet, but only finger tight. Replacement packing sets are available from the factory.

REPLACING Valve Stem Packing

1. Remove the valve assembly from the actuator. See section on “Removing Valve Body Assembly”. Do not grip or scratch the polished stem surface. This polish is part of the sealing system.
2. With the valve fully closed, measure and record the location of the two stem locknuts relative to their distance from the face of the bonnet. This dimension will be required for reassembly.
3. Loosen and remove both stem locknuts.
4. Remove the packing nut from the valve bonnet.
5. Remove all old packing, adapters and spring from the valve bonnet. One technique is to admit a small amount of pressure into the valve body until the packing is forced out of the stuffing box. Shield the bonnet as some spray may occur as the packing emerges.

DO NOT SCRATCH THE BORE OF THE STUFFING BOX WITH SHARP TOOLS.

6. Clean all surfaces of the stuffing box and stem. Remove all accumulations of mineral deposits or other debris before re-building. A .4375 diameter reamer is ideal to remove deposits from the bonnet, if the bonnet is removed from the body. A .45 diameter brass brush is often also very effective. Do not use abrasives on the valve stem nor in the stuffing box since scratches will cause leakage. The valve stem originally was polished to a 12 micro-inch finish and this polish should be preserved. If the stem is corroded, worn or marred it must be replaced. See section on “Reversing Valve Action”.
7. Blow all debris from the stuffing box and the replacement packing before re-building.
PACKING MUST BE CLEAN & FREE OF FOREIGN MATERIAL.

8. Install new packing as follows:

A) – Spring

B) – Male adapter with flat side in first against spring.

C) – V rings with lips in first. (3 pieces)

“V” rings must be carefully installed over the stem threads and into the stuffing box bore to avoid snagging of the lips on threads of bore entrance since the clean edge on these lips is imperative for proper sealing.

D) – Female adapter with cavity in against “V” rings and flat side out.

E) – Packing nut.

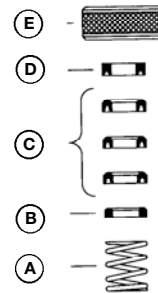

9. Tighten packing nut all the way down onto the bonnet to push all rings down into the stuffing box and to obtain proper spring load on the assembled rings. **TIGHTEN FINGER TIGHT ONLY.**
10. Replace the stem locknuts and re-position and lock in place as previously measured in step 2. If this dimension is not available, see section on “Replacing Valve Body Assembly” and use the dimension as described in the table there
11. Re-assemble Valve Body to Actuator as shown in section titled “Replacing Valve Body Assembly”.

CHECKING THE REGULATOR FOR PROPER ACTION

The thermal actuator will become inoperative if any leak occurs in the thermal system, allowing the pressure to escape from the system. This will in turn cause the bellows to retract upward causing the regulator to control as if the measured process had turned very cold. i.e. A heating valve will fully open and a cooling valve will fully close. (See section on Model 91600 for different response of "Safety-Type" actuator.)

CAUTION:
NEVER SEPARATE YOKE FROM CAP.
Removal of the four screws can cause injury due to
the rapid expansion of pressurized bellows and captive spring tension.

INSPECTING the Actuator

On the **Model 91400** the dial thermometer is an integral part of the thermal system. To check the thermal system for action simply read the dial thermometer. If, with the valve still attached, the dial thermometer is reading a proper temperature the actuator is good. If the dial thermometer is reading a very low temperature, possibly completely off of and below the scale, then the thermal system is most likely dead and needs to be replaced.

On all other model of actuators:

1. Record the current adjusting screw setting relative to the reference scale.
2. Set the adjustment screw to approximately "5" on the reference scale.
3. Remove the sensing bulb from the thermowell or process.
4. Subject the sensing bulb alternately to temperatures near the high and low limits of the nominal range of the instrument. This nominal range can be found on a tombstone shaped aluminum tag hanging from the tubing.
5. If stem motion up and down of over a 1/4" is observed then the actuator is good.
6. If no motion is seen, remove the actuator from the valve body. See section on "Removing Valve Body Assembly".
7. Repeat steps 2 – 5.
8. If no motion is seen, then the actuator is dead and needs to be replaced.
 - A) Obtain a replacement actuator and install onto the existing valve.
(See section on "Replacing Valve Body Assembly")
 - B) Finish re-installation of actuator and set adjusting screw to previously recorded reference number.
 - C) Restart as if a new installation per this instruction manual.
9. If motion is seen, the actuator is good. Set adjusting screw back to recorded reference mark and then inspect the valve for proper operation.

CHECKING THE REGULATOR FOR PROPER ACTION *(continued)***INSPECTING Valve Body Assembly**

1. Remove the Valve Body Assembly from the actuator.
(See section on “Removing Valve Body Assembly”)
2. By gloved hand, alternately push the valve stem down and pull up. There should be at least 1/4” of motion.
3. If no motion is seen, the valve is jammed.
 - A. Remove valve from line and inspect for debris caught between the valve seat and the valve plug preventing the valve from closing.
Disassembly of the valve may be required. (See section on “Reversing Valve Action”)
4. If debris is successfully removed and valve reassembled, repeat step 2.
5. If no motion is seen, obtain a new valve.
6. If valve is now working, or new valve obtained, reassemble valve to actuator.
(See section on “Replacing Valve Body Assembly”)

VALVE BODY ASSEMBLY

REMOVING Valve Body Assembly

1. Allow the sensing bulb on the actuator to cool to the bottom of the nominal range. Artificially cool with ice if necessary.
2. Record the current actuator adjusting screw setting relative to the reference scale.
3. Turn the actuator adjusting screw in (up) to reference number 8.
4. Hold the hexagonal actuator stem with a 5/16" wrench. With a 3/8" wrench, hold the two stem locknuts as a wrench flat and loosen the valve stem from the hexagonal actuator stem.
DO NOT DIRECTLY GRIP THE ROUND POLISHED PORTION OF THE VALVE STEM.
5. Remove the Bonnet Nut holding the actuator to the valve with a 1 1/2" wrench.
6. Unscrew the valve stem from the actuator stem by turning the entire valve body. If the valve body is still in-line, then unscrew by gently turning the valve stem, gripping it ONLY by the 3/8" hex nuts. Do not directly grip the round polished portion of the valve stem.
 - A. Make sure the valve plug is off of the valve seat while turning valve stem to prevent galling of the seating surfaces.
 - B. The above instructions will assure a heating valve plug is off of the seat. On a cooling valve it may not be possible to lower the valve plug off of the seat. If it is not possible to make sure the valve is open, then while holding the valve stem stationary gently turn the actuator stem to unscrew.

IF MODEL 91600 SEE SPECIAL INSTRUCTIONS FOR MODEL 91600.
7. The Valve and the Actuator may now be separated.

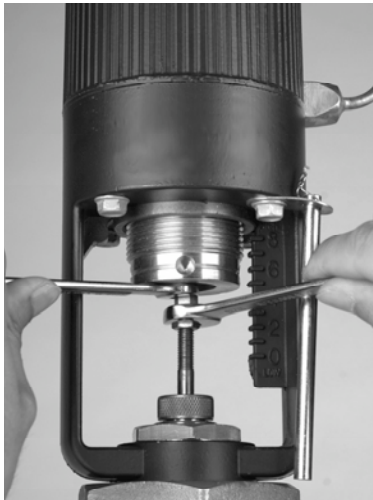

Figure 3

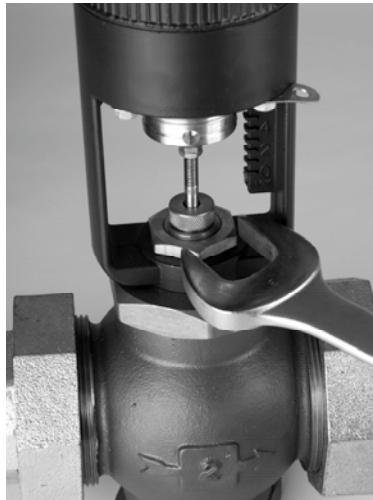

Figure 4

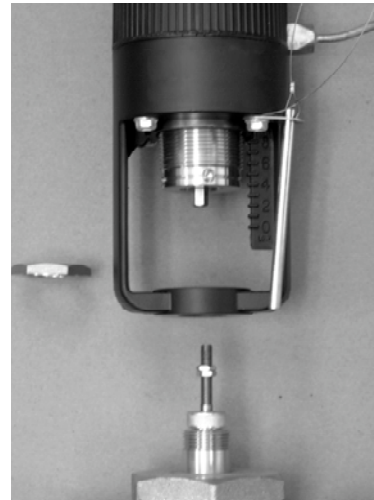

Figure 5

VALVE BODY ASSEMBLY *(continued)*

REPLACING Valve Body Assembly

1. Unless already completed, install two locknuts onto valve stem.
 - A) Thread locknuts loosely onto the valve stem.
 - B) Push or pull the valve stem as appropriate to fully CLOSE a two way valve. For a three-way valve pull the stem full OUT.
 - C) Set the topmost locknut to the dimension shown and tabulated in Figure 6.
 - D) Tighten the lower locknut up against the upper locknut making sure that the nuts are tight enough against each other to prevent further turning about the valve stem.

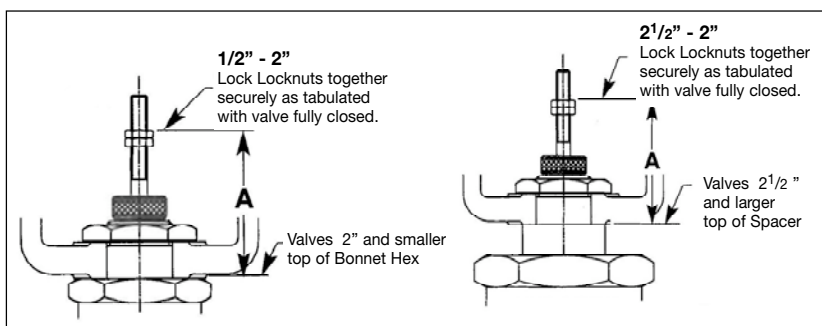

Figure 6

Valve Size NPT	Dim. A	
	ACTION	
	IN to CLOSE	OUT to CLOSE
1/4"-1/2"	2 1/4"	2 3/8"
3/4"	2 3/16"	2 3/8"
1"	2 3/16"	2 3/8"
1 1/4"	2 1/8"	2 3/8"
1 1/2"	2 1/8"	2 3/8"
2"	2 1/8"	2 3/8"
2 1/2"	2 1/8"	2 3/8"
3"	2 1/8"	2 3/8"
4"	2 1/8"	2 3/8"
5"	2 1/8"	2 3/8"
6"	2 1/8"	2 3/8"

* 2 1/2" size valves and above
"A" Dimension is from top of spacer
to the top of Lock nuts.

3-Way Valves - Stem Out	
Size - NPT	Dimension "A"
1/2" thru 2"	2 3/8"
2 1/2" thru 6"	2 3/8"

IF MODEL 91600 SEE SPECIAL INSTRUCTIONS FOR MODEL 91600

2. Allow the sensing bulb on the actuator to cool to the bottom of the nominal range. Artificially cool with ice if necessary.
3. Record the current actuator adjusting screw setting relative to the reference scale.
4. Turn the actuator adjusting screw in (up) to reference number 8.
5. Place valve stem up through the Yoke and Bonnet Nut.
6. Thread the valve stem into the actuator stem.
 - A. Use a 5/16" wrench to hold or turn the actuator stem.
 - B. Use a 3/8" wrench to hold the valve stem nuts to turn the valve stem.

DO NOT DIRECTLY GRIP THE ROUND POLISHED PORTION OF THE VALVE STEM.

If the valve plug can remain open relative to the valve seat, turn the valve stem into the actuator stem until the locknuts are tight against the actuator stem.

If the valve plug is closed against the valve seat, then gently turn the actuator stem down onto the valve stem until the actuator stem is tight against the locknuts.

IF MODEL 91600 SEE SPECIAL INSTRUCTIONS FOR MODEL 91600.
7. Tighten the Bonnet Nut down onto the bonnet to hold the valve body assembly to the yoke. Use a 1 1/2" wrench.
8. Return the actuator adjusting screw to the previously recorded reference setting.

REVERSING THE VALVE ACTION

1/2" – 2" Valve Sizes Only

Stem **In-To-Close** valves close with temperature increase and inward stem motion. On a regulator these valves are used for HEATING.

Stem **Out-To-Close** valves close with temperature decrease and outward stem motion. On a regulator these valves are used for COOLING.

1/2" through 2" Bronze Body valves use the same parts for both versions, and as such can be changed from one form to the other in most any shop.

**Stem moves in to body
to close assembly.**

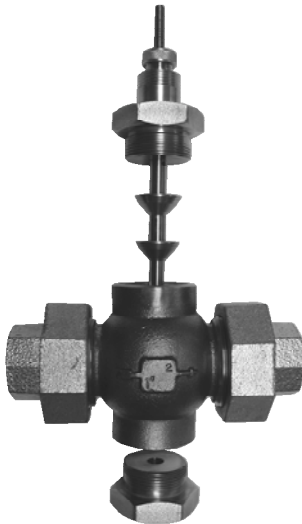

Figure 7



Figure 8



Figure 9

REVERSING THE VALVE ACTION *(continued)*

Procedure

1. Remove the valve body from the actuator as instructed in "Removing Valve Body Assembly".
2. Unlock and remove the two stem locknuts.
3. Carefully remove the stem packing. See "Replacing Valve Stem Packing". Place packing in a safe **CLEAN** area.
4. Using lengths of pipe in the union ends to hold the valve body, remove both the bonnet and the bottom plug from the valve body. See Figure 7. (Never use a wrench or vise on the bronze body.)
5. Look into the valve body on the side the valve plug was removed from. Make a note as to the appearance of the valve seats. The stainless steel valve seats are single sided. During reassembly the valve plug must be reinstalled through this side of the valve body.
6. Remove valve plug from bonnet as shown in Figure 7.
7. A cross pin secures the stem from rotating in the valve plug. Remove this pin carefully with a drift without marring the components. See Figure 8.
8. Unthread the stem from the valve plug. See Figure 9.

NOTE: The arrow cast on the valve body always points in the correct direction of flow for both assemblies.

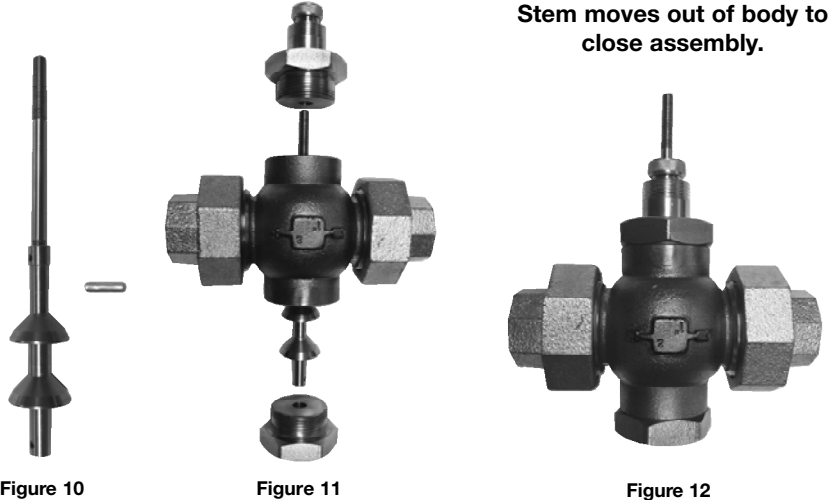

Figure 10

Figure 11

Figure 12

9. Thread the stem into the opposite end of the valve plug as shown in Figure 10.
 - A) Thread the stem in until the cross pin holes in the stem and the valve plug are centered upon each other.
 - B) Check the centering by making an extra 1/2 turn to see if this improves the centering. If not then 1/2 turn back.
10. Replace the cross pin.
 - A) If the holes are aligned correctly, when holding the valve plug by the valve stem and shaking it like a rattle, an audible rattle will be both felt and heard.
 - B) The cross pin must not protrude from either side of the valve plug.
11. The valve may now be assembled with the valve plug entering the valve body from the side presenting the stainless steel seat faces. See Figures 11 & 12. Note that the arrow cast on the side of the body appears to have been reversed, and (not shown in the picture) the lettering on the other side is now upside down relative to when you started.
12. Carefully slide the bonnet over the valve stem and attach to valve body using a suitable thread compound.
13. Reinstall the packing set. See "Replacing Valve Stem Packing".
14. Install the bottom plug using a suitable thread compound.
15. Replace the locknuts and reassemble the valve to the actuator per the instructions in the section "Replacing the Valve Body Assembly".

3 WAY-REGULATORS – Installation & Maintenance

The Actuators on these regulators are identical to those previously described and the bulb installation is also identical. These valves require three piping connections and can be used to diverge the flow to either of two outlets, or to converge two inlets into one outlet. Port C is normally closed and Port B closes as temperature increases. Port A is the common port and remains open.

for Mixing or Diverting

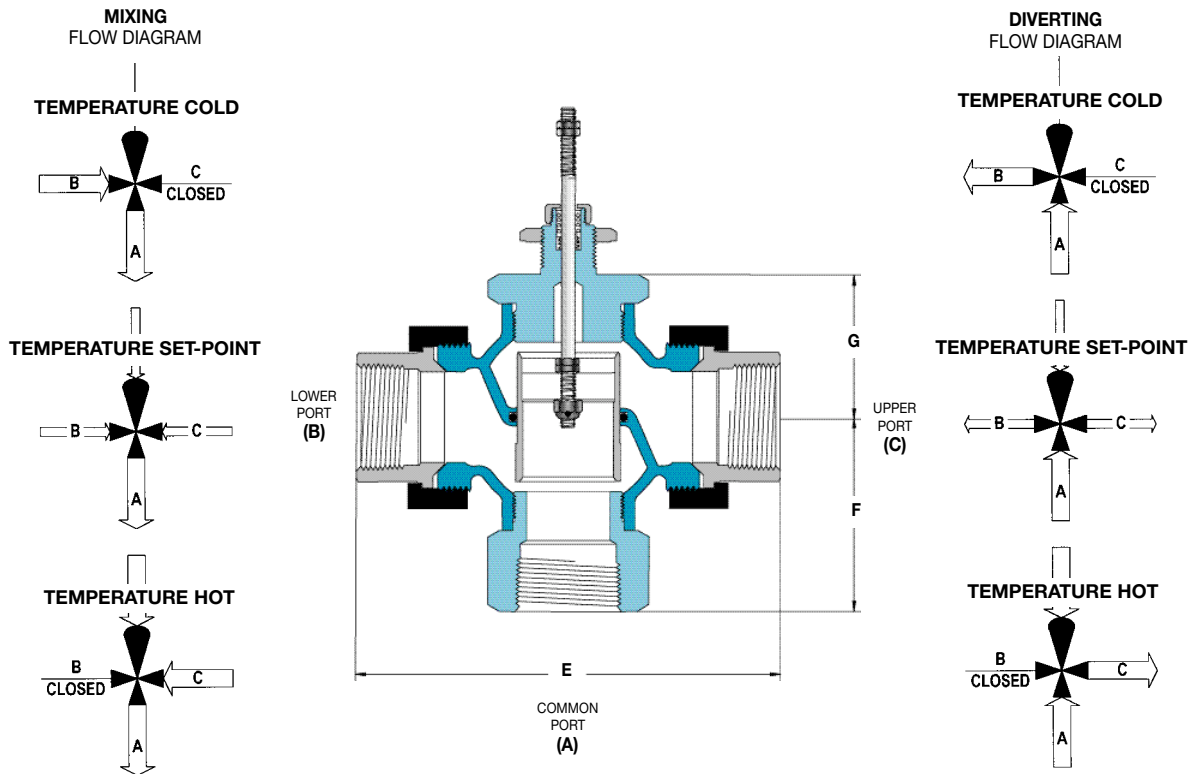

MIXING: Inlet pressures must be equal and check valves are recommended in inlets.

DIVERTING: Outlet pressures must be close to equal to provide consistent pressure differential both ways if partial flows must be maintained.

NOTES: This valve not to be used for Steam or Temperatures over 350°F.

1/2" thru 2" sizes union ends 2 1/2" thru 4" sizes flanged ends.

Model 91600 “SAFETY-TYPE” – Installation & Maintenance



Model 91600 shown

The valve body assemblies on these models are identical to those previously described and there is no difference in their servicing. However, the actuators are different and larger bellows are used to develop adequate thrust with the limited pressure differential available below atmospheric pressure. If the “Safety-type” tube system becomes damaged and inoperative, the valve will move toward the hot position within the listed working conditions. If subjecting the thermal bulb alternately to temperatures above and below the instruments range does not produce any valve stem movement, the system is dead and requires replacement or factory service.

FACTORY SERVICE

If you are unable to obtain proper operation of the regulator, we suggest you contact the nearest Trerice representative. If necessary, the regulator will be sent to the factory on a “check and Report” basis and the regulator will be thoroughly inspected and tested.

Model 91600 – SPECIAL INSTRUCTIONS

91600 Stem

The actuator stem in a Model 91600 actuator does not turn. When removing or attaching the valve stem to the actuator stem on a Model 91600 regulator turn the valve stem only.

- On a cooling valve the sensing bulb must be heated in a bucket of hot water to extend the stem to displace the valve plug off of the valve seat to prevent damage to the valve seat.
- On a heating valve the sensing bulb must be cooled in a bucket of ice to retract the stem to displace the valve plug off of the valve seat to prevent damage to the valve seat.

91600 Stem Locknuts

When setting the stem locknut dimensions the In-To-Close valves used on 91600 Actuators are to be set 1/4” shorter than shown in Figure 6. Out-to-Close and three-way valves are set the same as tabulated.

Over Range Protection

The Model 91600 does not incorporate over-range protection. Do not exceed the maximum temperature shown on the instrument.

TYPICAL APPLICATIONS

Typical Heat Exchanger Application Using a Self-Op 2-Way Valve

<p style="text-align: center;">HEATING Use an In-to-CLOSE Valve</p>
<p style="text-align: center;">COOLING Use an In-to-OPEN Valve</p>

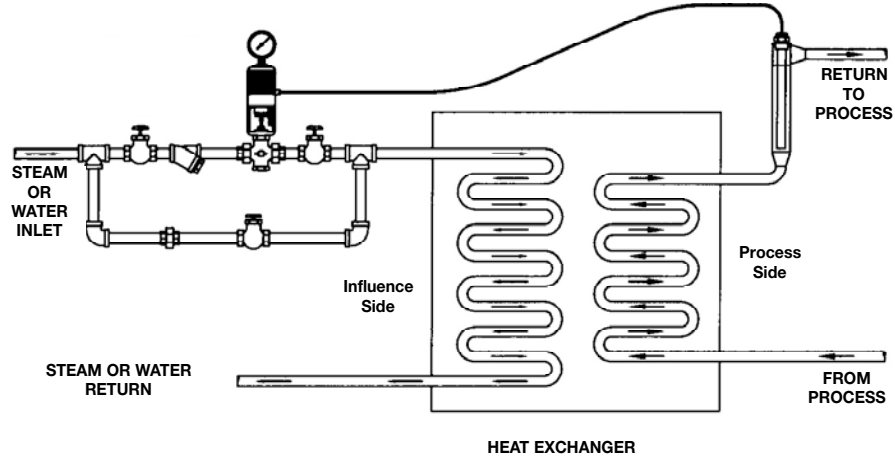

Typical Heat Exchanger Application Using a Self-Op 3-Way Diverting Valve

<p style="text-align: center;">HEATING Connect Upper Port (C) to Water / Glycol Return and Lower Port (B) to Heat Exchanger</p>
<p style="text-align: center;">COOLING Connect Upper Port (C) to Water / Glycol Return and Lower Port (B) Water / Glycol Return</p>

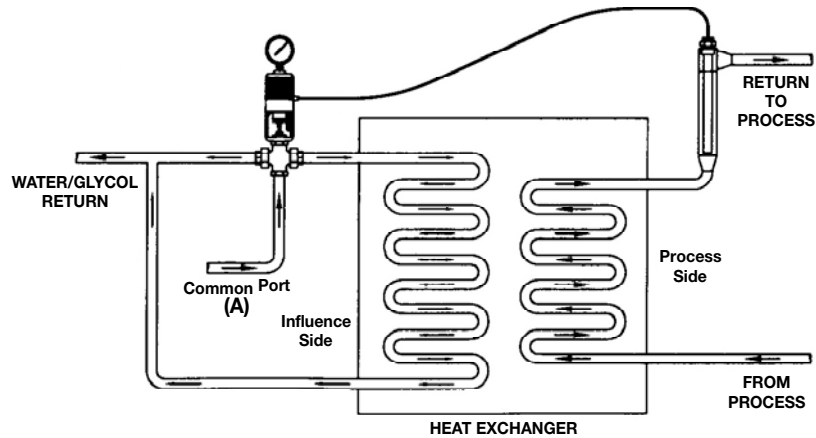

Typical Plumbing for a Self-Op 3-Way Mixing Valve

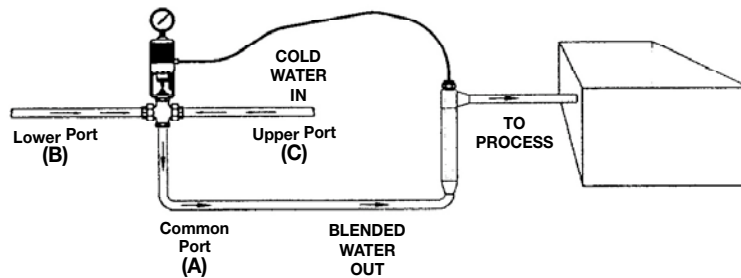

TYPICAL APPLICATIONS

Typical Heating Application Using a Self-Operating Temperature Regulator

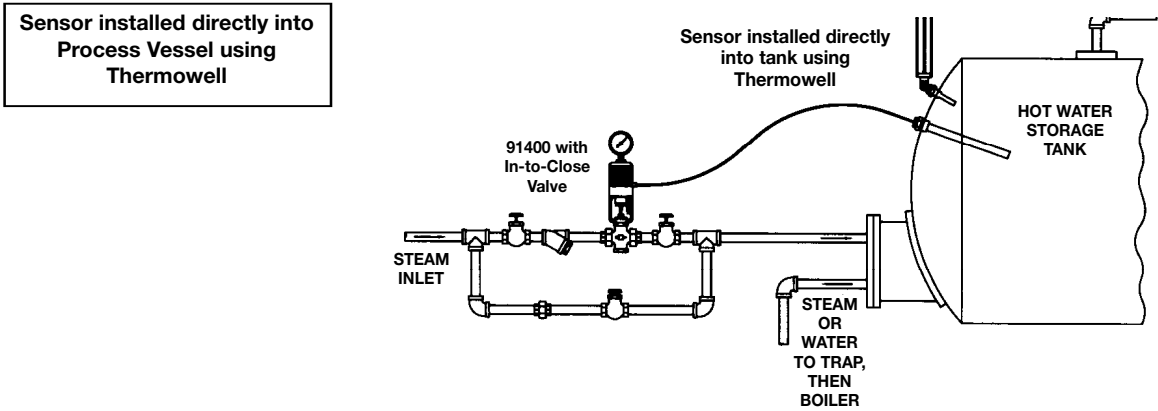

Typical Heat Exchanger Application Using a Self-Operating Temperature Regulator

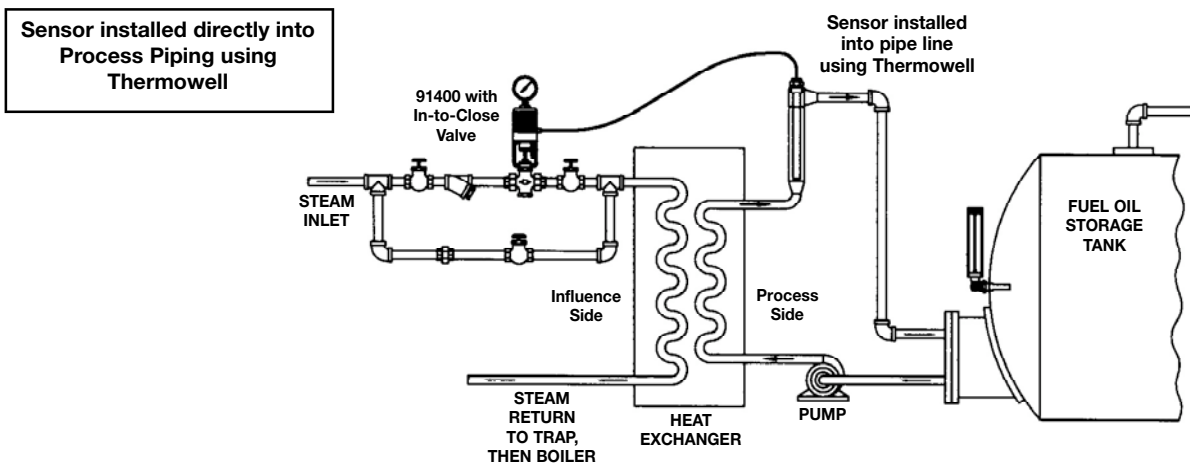

Typical Plating or Pickling Application Using a Self-Operating Temperature Regulator

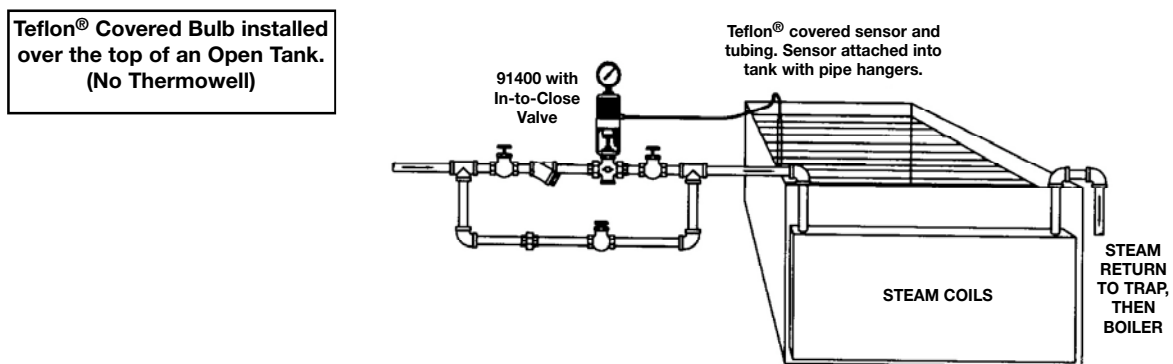

TROUBLE SHOOTING GUIDE

PROBLEM: ERRATIC CONTROL

CAUSES		CORRECTIONS
1. Bent or binding valve stem.	➔	1. Replace with free running stem.
2. Packing binding valve stem.	➔	2. Replace packing set.
3. Poor bulb location.	➔	3. Relocate bulb to more representative average temperature location or add agitation.
4. Sudden load changes requiring greater capacity than valve size can handle.	➔	4. Replace with proper size valve.
5. Wide changes in valve inlet pressure – more pronounced with unbalanced single seal valve.	➔	5. Maintain more stable inlet pressure.
6. Over sized valve.	➔	6. Replace with proper valve.

PROBLEM: TEMPERATURE EXCEEDS THE DESIRED CONTROL POINT

CAUSES		CORRECTIONS
1. Adjusting setting too high.	➔	1. Lower setting.
2. Bulb at cold location.	➔	2. Relocate bulb to more representative average temperature location or add agitation.
3. Tube system assembly has lost pressure fill.	➔	3. Replace the thermal actuator.
4. Stem adjustment too short.	➔	4. Readjust. (See Figure 6)
(Closes with temperature increase)		
5. Foreign material under seats holding valve open.	➔	5. Cool the bulb to open the valve and allow it to clean out.
6. Erosion of seats with resulting high leakage.	➔	6. Repair or replace valve body assembly.
7. Pressure drop across valve is too high.	➔	7. Reduce pressure drop or replace single seated valve with with double seated.
8. Stem moves into body to open valve.	➔	8. Change to stem moves into body to close valve.
(Opens with temperature increase)		
9. Valve size too small.	➔	9. Increase supply pressure or replace valve with larger size.
10. Valve inlet pressure too low.	➔	10. Increase supply pressure or replace valve with larger size.
11. Heat exchanger is not large enough.	➔	10. Replace with proper capacity.
12. Stem moves into body to close valve.	➔	10. Change to stem moves into body to open valve.
13. No flow or temperature to bulb.	➔	13. Add by-pass flow line.

TROUBLE SHOOTING GUIDE

PROBLEM: TEMPERATURE REMAINS BELOW THE DESIRED CONTROL POINT

CAUSES	→	CORRECTIONS
1. Adjusting setting too low.	→	1. Raise setting.
2. Bulb at hot location.	→	2. Relocate bulb to more representative average temperature location or add agitation.
3. Stem adjustment too long.	→	3. Readjust. (See Figure 6)
(Closes with temperature increase)		
4. Valve size too small.	→	4. Replace valve with larger size.
5. Valve inlet pressure too low.	→	5. Increase supply pressure.
6. Heat exchanger not large enough.	→	6. Replace with proper capacity.
7. Faulty or undersized steam trap.	→	7. Install trap of proper capacity.
8. Stem moves into body to open valve.	→	8. Change to stem moves into body to close valve.
(Opens with temperature increase)		
9. Foreign material under seats holding the valve open.	→	9. Heat the bulb to open the valve and allow it to larger size.
10. Erosion of seats with resulting high leakage.	→	10. Repair or replace valve body assembly.
11. Pressure drop across the valve is too high.	→	11. Reduce pressure drop or replace single seated valve with double seated.
12. Stem moves into body to close valve.	→	12. Change to stem moves into body to open valve.



Manufacturer of:

Pressure Gauges • Temperature Instrumentation • Regulators & Control Valves

TRERICE Corporate Headquarters
Customer Service and International Sales
12950 W. Eight Mile Road, Oak Park, Michigan 48237
Toll Free: 1-888-873-7423
Fax: 1-248-399-7246
www.TRERICE.com

Regional Sales Offices

Northeast
Philadelphia, PA

Central East
Buffalo, NY

Midwest
Chicago, IL

Canada
Toronto, ON

South & Southeast
Atlanta, GA

West
Seattle, WA

Mexico
Mexico, CP