

INSTRUCTIONS FOR

THE OPERATION, INSTALLATION AND MAINTENANCE
OF NO. 91000XT SERIES SELF-OPERATING REGULATOR
ON HEATERS AND TREATERS IN
THE OIL PRODUCING INDUSTRY

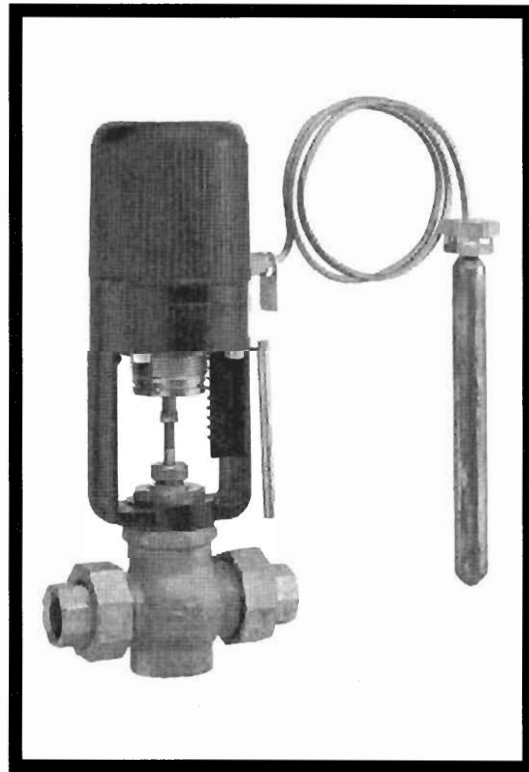

 **TREYER**
TEMPERATURE • PRESSURE • CONTROL

Trerice

INSTALLATION AND MAINTENANCE INSTRUCTIONS

INDEX

	Page No.
Capacity table.....	9
Checking the Actuator	4
Dimensions & Drawings.....	8
Factory Service	9
Installation of the bulb	2
Installation of the regulator.....	2
Operation.....	2
Packing gland.....	6
Placing in operation and setting control point.....	3
Recommended location for regulator	2
Removing valve body assembly	5
Replacing the actuator	4
Replacing valve body assembly.....	5
Servicing	4
Trouble shooting guide	9
Typical application	7
Valve stem packing.....	6

GUARANTEE

The H. O. TRERICE CO. guarantees products of its manufacture to be free from defects in workmanship and material for a period of one year from the date of shipment to the original purchaser, and will repair or replace such products, F.O.B. Factory, which our examination shall reveal to be defective. We assume no other responsibility. Equipment and specifications are subject to change without notice.

Trerice

Installation And Maintenance Instructions

The TRERICE Series No. 91000XT temperature regulator operates on the vapor pressure principle. The sensitive bulb of the instrument contains a fluid that creates a vapor pressure which increases or decreases as the sensitive bulb temperature increases or decreases. This vapor pressure is transmitted to the bellows which, opposing the adjusting spring, actuates the valve controlling the flow in proportion to the bulb temperature. Raising or lowering the adjusting screw creates more or less force of the spring against the bellows thus raising or lowering the control temperature. For the most sensitive operation a range should be selected locating the control point in the upper portion. The vapor pressure response is greater per unit of temperature change in the upper portion of the range. All TRERICE standard regulators in sizes thru 3" are provided with an over-range protection feature which allows the bulb to be heated 100°F over the controlled temperature without damaging the system.

DECIDING THE LOCATION FOR THE REGULATOR

The regulator should be installed in an accessible location on horizontal piping. Possible damage from moving parts, splashing of corrosive liquids, vibration, heat, etc., should be considered in deciding the location. Similar consideration should also be given the capillary tubing and bulb. The capillary tubing on high range instruments should be located where the temperature is at least 20°F cooler than the control point.

REGULATOR INSTALLATION

A strainer should be installed just ahead of the regulator to protect the valve from dirt, scale or foreign matter which could interfere with the seating of the valve. A three valve by-pass installed around the regulator will facilitate removal for service. Blow out all pipe lines thoroughly to eliminate all foreign material from the system. Pipe thread compound should be applied only on external or male threads. Install the regulator in a vertical position with the flow direction thru the valve corresponding to the arrow cast on the body. Tighten tailpieces of unions on piping first and then tighten both valve union nuts simultaneously.

BULB INSTALLATION

The location of the bulb is important. The bulb or socket must be totally immersed in an average temperature location which is representative of the whole volume being controlled. It should not be situated near hot or cold spots. If the regulator is to control a corrosive fluid the bulb or well must be of suitable material. Never install the bulb with the capillary end down unless it has been specifically ordered for this position.

Apply heat transfer paste to the bulb before final insertion into well.

To install a union connected bulb, first install the well. Then slip the bulb into the well and tighten the coupling nut. Never attempt to tighten or loosen a well without first loosening the coupling nut, since this would twist the capillary tubing and promote failure.

Keep all bends in capillary tubing greater than a 1½" radius. Do not subject tubing to repeated flexing, vibration, heat, cutting, kinking or other abuse. Coil all excess capillary tubing and place in a cool location. Capillary must be supported to prevent whipping.

Treerice

INSTALLATION AND MAINTENANCE INSTRUCTIONS

PLACING IN OPERATION AND SETTING CONTROL POINT

Turn the adjusting screw to a position on the "0 to 8" reference scale that approximately corresponds to the position of the desired control point within the adjustable range. The "V" slot in the adjusting screw is intended as an index line for reference in obtaining desired settings. To raise the control point, turn the regulator adjusting screw from left to right toward "HIGH". To lower the control point, turn from right to left toward "LOW". Insert the bar attached to the regulator into holes in the adjusting screw to turn this adjustment.

See Figure 1.

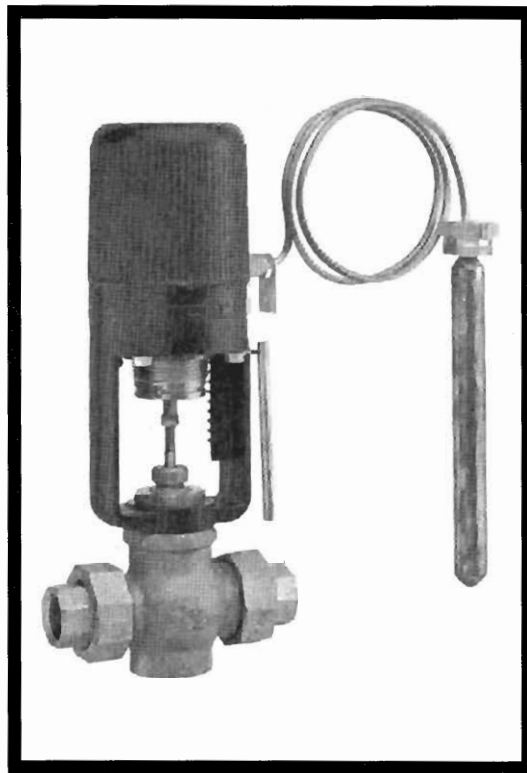

Figure 1

CAUTION: DO NOT TURN SCREW BELOW THE "O" MARK

Observe the control point after it stabilizes and re-adjust the screw as required to obtain the desired control point. Initial over shooting may occur until the system approaches equilibrium. Allow sufficient time for correction to take place each time before changing the setting.

Treerice

INSTALLATION AND MAINTENANCE INSTRUCTIONS

Servicing

Since this instrument is self contained and practically trouble free, very little maintenance is required. An occasional drop of oil on the valve stem at the packing gland will prolong packing life and maintain freedom of motion of the stem which is essential for close control. See figure 2.

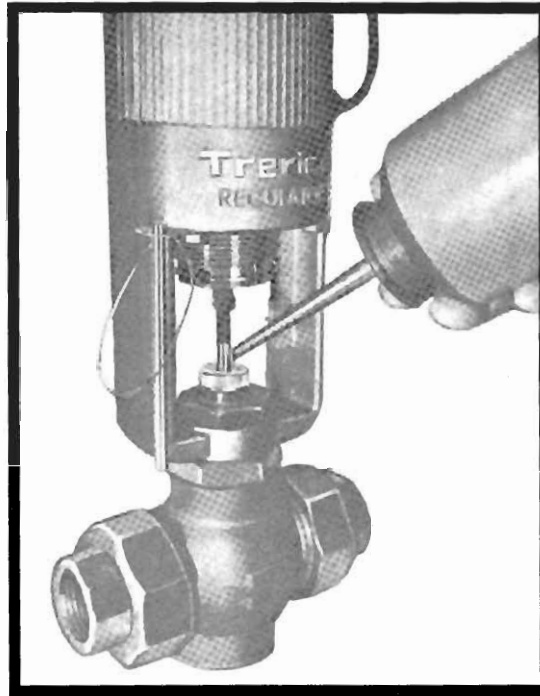

Figure 2

Leakage should never be tolerated. Any leak at bonnets, unions, plugs, etc. requires immediate correction to avoid serious damage which may result in factory service or replacement.

Checking The Actuator Assembly

The actuator assembly will become inoperative if any leak occurs in the system, allowing the pressure to escape from the system. This will in turn allow the control point to rise above the setting point. To test the system, first set the adjusting screw between 4 and 6 on the reference scale.

Now subject the bulb alternately to temperatures near the top and then the bottom of the range and watch for valve stem movement. If no movement occurs, the system is dead and will require factory repair or replacement.

Replacing The Actuator

Follow instructions for removing and replacing the valve body, but attach new actuator to old body assembly.

Treerice

INSTALLATION AND MAINTENANCE INSTRUCTIONS

Removing Valve Body Assembly

First allow the bulb to cool and turn the adjusting screw up to figure 8 on the adjustment scale. Now loosen the two stem locknuts (part number 2012) and remove the valve bonnet nut holding the yoke to the valve with a 1-1/2" end wrench. Turn the valve and stem to unscrew the stem and remove the valve from the yoke. See Figures 3, 4, and 5. If necessary, the two stem locknuts may be locked together to provide a wrench grip for turning the valve stem out. Never grip the smoothly finished stem itself since any marring of this finish will impair valve function and reduce packing life.

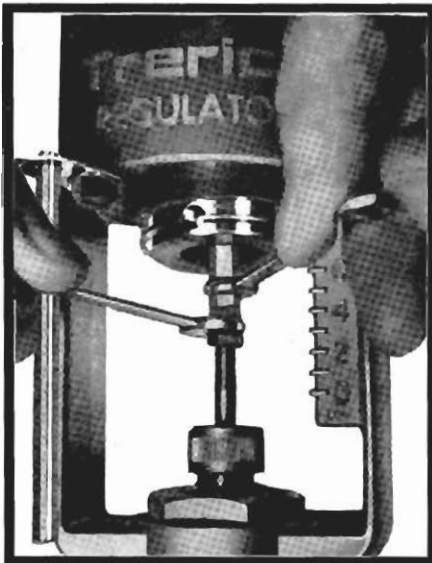

Figure 3

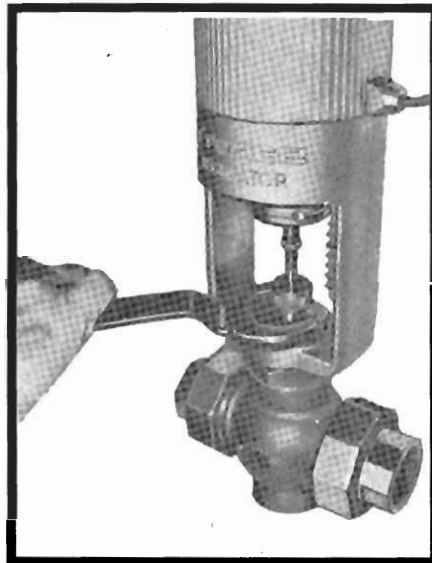

Figure 4

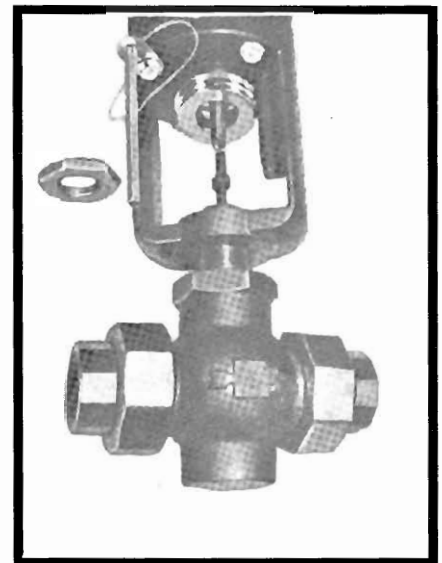

Figure 5

Replacing Valve Body Assembly

To install valve, lock stem locknuts in position shown in Figure 6, right. Place stem thru yoke and valve bonnet nut. Turn valve stem into regulator stem up to locknuts and securely tighten together. Tighten valve bonnet nut.

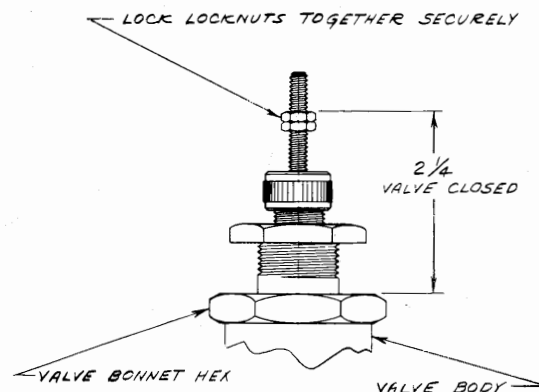

Figure 6

Treerice

INSTALLATION AND MAINTENANCE INSTRUCTIONS

The Packing Gland

The regulator uses teflon "V" ring packing sets with male and female adapters used as end rings and a stainless steel compression spring. The spring loading of the packing maintains proper compression of the rings and also compensates for wear that occurs at the seals. No adjustment is needed and the packing nut should be threaded all the way onto the bonnet. Replacement packing is available from the factory.

Replacing Valve Stem Packing

1. Remove actuator from the valve assembly bonnet. This is done by removing the valve bonnet nut holding the yoke to the bonnet and unscrewing the valve stem from the regulator stem. Use the two stem locknuts as a wrench grip to turn the valve stem. If the nuts should turn on the stem, lock them more tightly together so that the stem will turn. Never grip the polished stem itself since marring of this finish will result in a stem that is impossible to repack and seal properly. The 5/16" hexagon actuator stem must be held from turning while loosening the valve stem. If the valve is in the closed position, hold the valve stem stationary and unscrew the 5/16" hexagon actuator stem to avoid galling of valve trim by turning of the plug against the seat. See figures 3, 4 and 5.
2. Before loosening the stem locknuts measure and record the location of the nuts from the end of the stem so that they can later be re-positioned to the original location. Remove both locknuts from the stem.
3. Remove the packing nut from the valve bonnet.
4. Remove all old packing, adapters, washers and spring from the valve bonnet. This is most easily accomplished by admitting a small amount of pressure to the valve body until the packing is forced out of the stuffing box. Shield the bonnet as some spray may occur as the packing emerges. **DO NOT SCRATCH BORE OF STUFFING BOX WITH SHARP TOOLS.**
5. Clean all surfaces of the stuffing box and stem. Remove all accumulations of mineral deposits or other debris before re-building. A .4375 diameter reamer is ideal to remove deposits from the bonnet, if the bonnet is removed from the body. Do not use abrasives on the valve stem since scratches will cause leakage. The stem originally was polished to a 12 micro-inch finish and this polish should be preserved. If the stem is corroded or worn or marred it must be replaced.
6. Blow all debris from the stuffing box and the replacement packing before re-building. **PACKING MUST BE CLEAN & FREE OF FOREIGN MATERIAL.**
7. Install new packing as follows:
 - A— Spring
 - B— Male adapter with flat side in first against spring.
 - C— V rings with lips in first
 - D— Female adapter with cavity in against V rings and flat side out
 - E— Packing nut
8. Tighten packing nut all the way down on bonnet to push all rings down into the stuffing box and to obtain proper spring load on the assembled rings.
9. Replace the stem locknuts and re-position and lock in place as previously measured before disassembly. If measurement was not available, use the dimension from the bonnet mounting face to the top surface of the top locknut as shown under Replacing Valve Body Assembly.
10. Reverse step No. 1 and replace actuator and bonnet nut and re-assemble stem connection again using the locknuts as wrench grips on the stem.

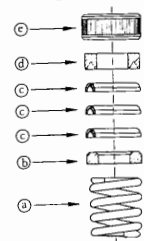

Treerice

SELF-OPERATING REGULATOR TYPICAL APPLICATION

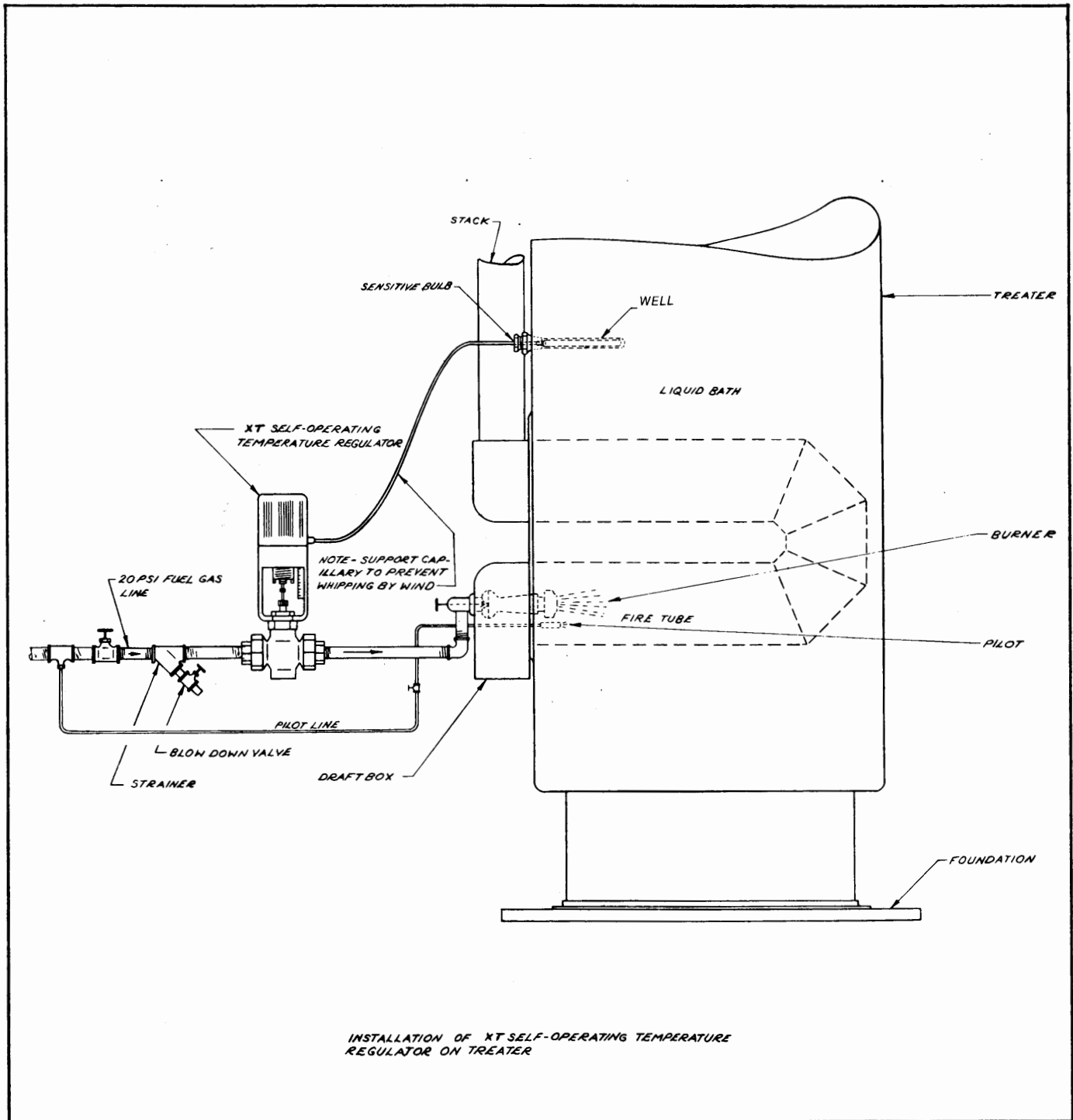

TROUBLE SHOOTING GUIDE

PROBLEM: ERRATIC CONTROL

Causes

1. Bent or binding valve stem.
2. Packing binding valve stem.
3. No lubricant in packing.
4. Poor bulb location.
5. Sudden load changes requiring greater capacity than valve size can handle.
6. Wide changes in valve inlet pressure – more pronounced with unbalanced single seated valve.
7. Over size valve.

Corrections

1. Replacing with free running stem.
2. Loosen and repack if necessary to stop leak.
3. Repack with lubricated packing.
4. Relocate bulb to more representative average temperature location or add agitation.
5. Replace with proper size valve.
6. Maintain more stable inlet pressure.
7. Replace with proper size valve.

PROBLEM: TEMPERATURE EXCEEDS THE DESIRED CONTROL POINT

1. Adjustment setting too high.
2. Bulb at cold location.
3. Tube system assembly has lost its pressure fill.
4. Foreign material under seats holding valve open.
5. Erosion of seats with resulting high leakage.
6. Pressure drop across valve is too high.

1. Lower setting.
2. Relocate bulb to more representative average temperature location or add agitation.
3. Replace actuator assembly.
4. Cool the bulb to open the valve and allow it to clean out.
5. Repair or replace valve body assembly.
6. Reduce pressure drop.

PROBLEM: TEMPERATURE REMAINS BELOW THE DESIRED CONTROL POINT

1. Adjustment setting too low.
2. Bulb at hot location.
3. Valve size too small.
4. Valve inlet pressure too low.
5. Heat exchange not large enough.

1. Raise setting.
2. Relocate bulb to more representative average temperature location or add agitation.
3. Replace valve with larger size.
4. Increase supply pressure.
5. Replace with proper capacity.

FACTORY SERVICE

If you are unable to obtain proper operation of the regulator, we suggest you contact the nearest Treerice representative as listed on the back of this manual. If necessary, the regulator will be sent to the factory on a "check and report" basis and the regulator will be thoroughly inspected and tested.

0.6 SPECIFIC GRAVITY GAS CAPACITY TABLE TANK REGULATORS – 1/2" PORT

INLET PSIG	5			10			20			30			40			50		
OUTLET PSIG	4	2	0	8	5	0	15	10	5	25	20	10	30	20	15	40	30	25
SCFH	970	1585	1935	1450	2140	2700	2685	3480	3870	3100	4120	5030	4650	6000	6200	5320	6870	7250



12950 W. Eight Mile Road • Oak Park, MI 48237-3288

Phone: 1-888- TRERICE Fax: 1-248-399-7246

Website: www.trerice.com

E-mail: info@trerice.com