

# Valve Body Selection

(for 940E Series Electric Motor Control Valve)

3-WAY • 1/2" – 2"

# STAINLESS STEEL

All dimensions are nominal. Dimensions in [ ] are in millimeters.



CONTROL VALVES

## Mixing

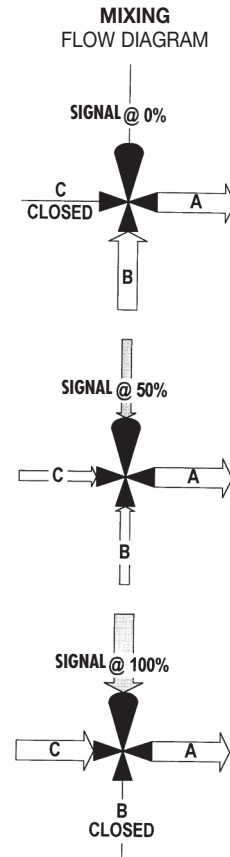
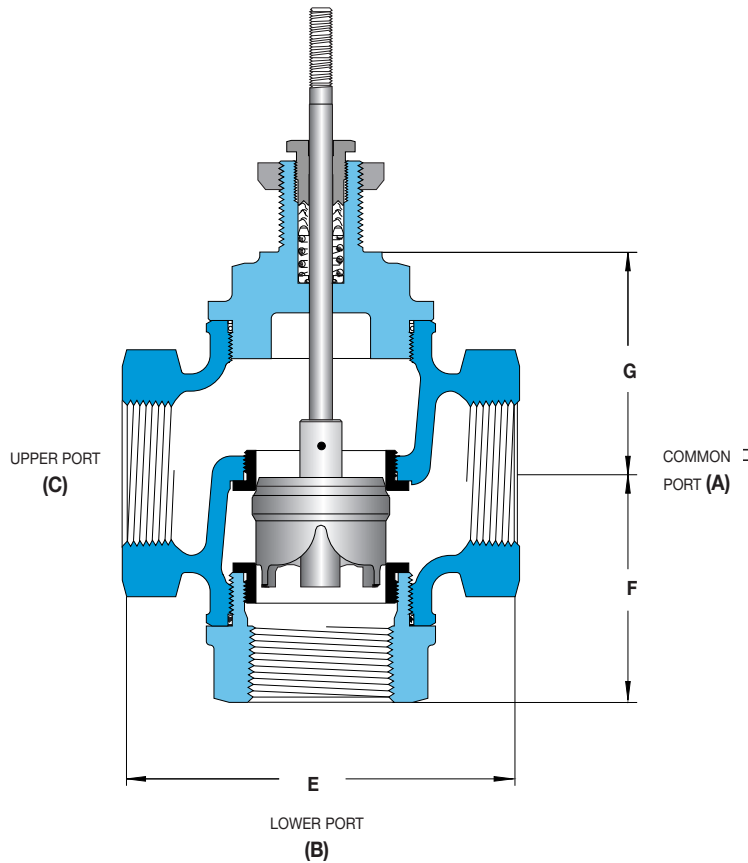

Trerice 3-Way Valves are not designed for use in steam applications.

## Specifications

Action	Body Material	Trim Material	Trim Style	Connection	Pressure & Temperature Rating
Mixing	Stainless steel	Stainless steel	Linear	Threaded	515 PSI @ 400°F (204°C)

## Valve Body Selection

Valve Body Number	Size Connection (NPT)    Nominal Port		C <sub>v</sub>	Maximum Close-Off Pressure (psid)				Dimensions			Approximate Shipping Weight
				Actuator Size 25		Actuator Size 26		E	F	G	
				Class III	Class IV	Class III	Class IV				
M18	1/2	1/2"	6.3	238	203	x	x	5.0 [127]	2.8 [71]	2.8 [71]	8 lbs [3.6 kg]
M25	3/4	3/4"	8.2	238	203	x	x	5.0 [127]	2.8 [71]	2.8 [71]	8 lbs [3.6 kg]
M34	1	1"	10	238	203	351	315	5.0 [127]	2.8 [71]	2.8 [71]	8 lbs [3.6 kg]
M56	1 1/2	1 1/2"	20	100	76	151	127	6.1 [155]	3.4 [86]	3.5 [89]	15 lbs [6.8 kg]
M67	2	2"	40	58	39	90	71	6.5 [165]	3.8 [97]	3.8 [97]	19 lbs [8.6 kg]