

# Thermowells

## DESIGN & OPERATION



### Description

A thermowell is a pressure tight receptacle designed to accept a temperature sensing element and provide a means to insert that element into a vessel or pipe.

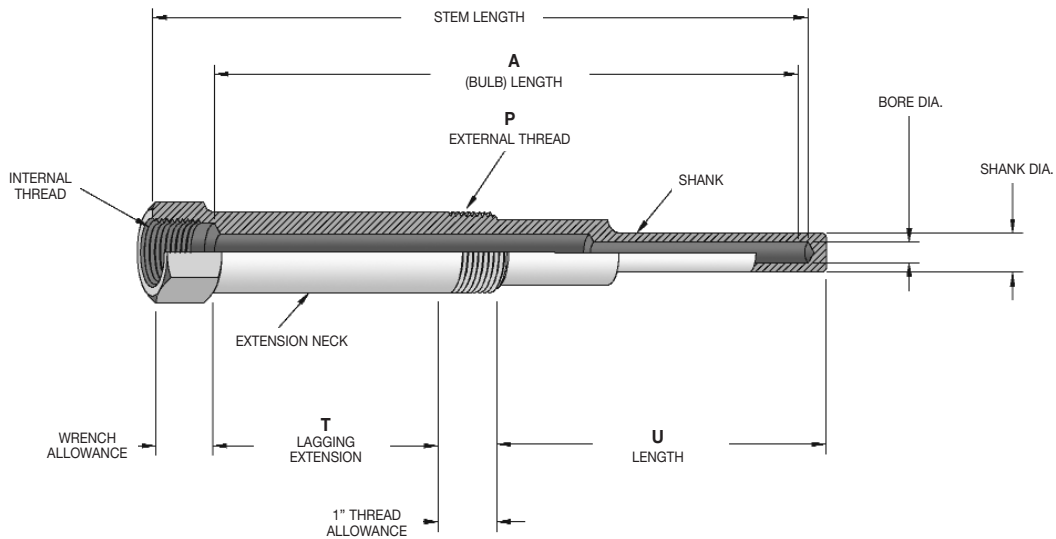

### Principles of Operation

A thermowell acts as a barrier between a process medium and the sensing element of a temperature measuring device. It protects against corrosive process media, media contained under pressure, or media flowing at a high velocity. A thermowell also allows the sensing element to be removed from the application while maintaining a closed system.

## Selecting a Thermowell

Temperature Instrumentation and Control Products, including: Thermometers, Thermocouples, RTDs, and Temperature Controllers.

**All Trerice Thermowells should be carefully selected to meet the demands of the particular application. The information contained in this catalog is only offered as a guide to assist in making the proper selection. Improper application may cause failure of the thermowell, resulting in possible personal injury or property damage.**

**To ensure minimum response time, Trerice Heat Transfer Paste should be applied to the sensing portion of the instrument before installation into a thermowell. 1 oz. tube: Item No. 107-0001**

### Connection

Trerice Thermowells are available in a variety of process connection styles. Threaded connections in 1/2, 3/4 and 1 NPT are the most widely specified. Socket weld, weld-in, raised face flanged, Van Stone flanged, and sanitary (Tri-Clamp) connection styles are also available.

All Trerice Bimetal Thermowells are provided with a 1/2 NPSM instrument connection to allow for pressure relief within the thermowell.

### U-Length

The U-length (insertion length) of a thermowell indicates its insertion depth into a process vessel or piping system and is measured from the tip of the thermowell to the underside of the threads. The U-length must equal or exceed the length of the sensitive portion of the temperature instrument's stem or bulb. Trerice Thermowells are available in U-lengths from 2" to 72".

### Material

The material chosen must be compatible with the process medium to which it is exposed. In applications of high pressure or velocity, the material may be chosen for its strength or durability. Trerice offers thermowells in a variety of materials, including: brass, carbon steel, stainless steel, Monel, Carpenter 20, Hastelloy B or C, Inconel 600, Incoloy 800, Nickel and Titanium. Other alloys or compounds may also be available, please consult factory.

Threaded, welded and Van Stone flanged thermowells are made from forgings or bar stock. Raised face flanged and sanitary thermowells are of a two-piece welded construction.

### Bore

The bore of each Trerice Thermowell is designed to fit the sensing element of a specific Trerice Temperature Instrument.

### Shank

Trerice Thermowells are available in stepped, tapered, and straight shank configurations. Stepped shank thermowells are normally used on standard duty applications. Tapered shank thermowells are designed for use on heavy duty applications. Straight shank thermowells are designed for use with instruments that have wide stem diameters or short stem lengths.

### Lagging Extension

Lagging extension thermowells are used on applications where insulation covers the vessel or piping system. The extension length (T-length) is the measurement between the instrument connection and process connection of the thermowell.