

Remote Mounted Dial Thermometer

4 1/2" • 6" • 8 1/2" Cast Aluminum Case

DIAL THERMOMETERS

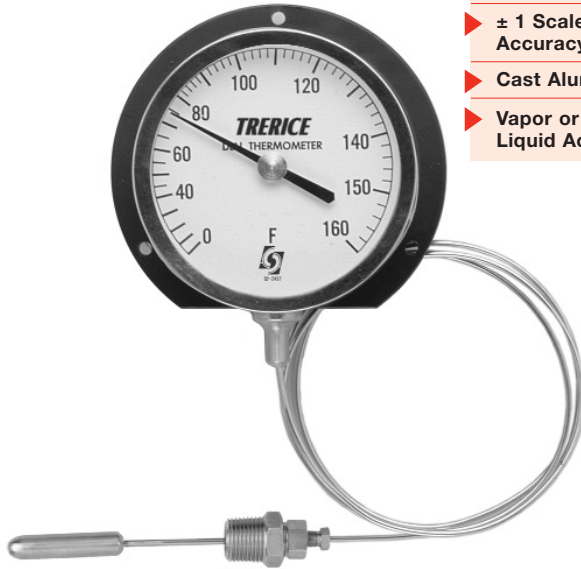

V80341 shown

- ▶ 4 1/2", 6", 8 1/2" Dial Sizes
- ▶ ± 1 Scale Division Accuracy
- ▶ Cast Aluminum Case
- ▶ Vapor or Liquid Actuated

This Trerice **Remote-Mounted Dial Thermometer** is furnished with a rugged cast aluminum case in 4 1/2", 6" and 8 1/2" dial sizes. This instrument is designed for a wide variety of industrial applications, and is available with vapor or liquid actuation.

- Optional features available: Please consult the Optional Features Section for details.

Thermowell

- For applications where the process media may be corrosive or contained under pressure, the use of a thermowell is required to prevent damage to the thermometer and facilitate its removal from the process.

(Refer to page 154)



HOW TO ORDER

Sample Order Number: **V 80341 050 B02 20**

Actuation	Model	Range Code	Thermal System	Capillary Length*
V Vapor	80341 4 1/2"	See Standard Ranges	See Thermal System Selection (pages 112-113)	05 5 Feet
L Liquid	80361 6"			10 10 Feet
	80381 8 1/2"			15 15 Feet
				20 20 Feet
	80342 4 1/2"			
	80362 6"			
	80382 8 1/2"			
	80345 4 1/2"			
	80365 6"			

* Other Capillary lengths available: Specify in feet. Vapor: 100 Feet Max
Liquid: 20 Feet Max

Specifications

Models	Dial Sizes	Case Styles
80341 80361 80381	4 1/2" 6" 8 1/2"	 Surface Mounted, back flanged, with bottom outlet
80342 80362 80382	4 1/2" 6" 8 1/2"	 Surface Mounted, back flanged, with back outlet
80345 80365	4 1/2" 6"	 Flush Mounted, hinged ring, with back outlet

Movement Brass

Case Material

Cast Aluminum, black finish

Window

Clear glass

Ring

Friction type, 304 stainless steel (hinged type, black finished aluminum; 80345, 80365 only)

Pointer

Adjustable, black finish

Dialface

Aluminum, white background with black graduations and markings

Accuracy

±1 scale division

Approximate Shipping Weight

4 1/2" Dial: 2.4 lbs [1.09 kg]

6" Dial: 3.0 lbs [1.36 kg]

8 1/2" Dial: 4.0 lbs [1.82 kg]

All dimensions are nominal. Dimensions in [] are in millimeters.

Surface Mount Back Flange Case Models 80341, 80361, 80381 (bottom outlet), Models 80342, 80362, 80382 (back outlet)

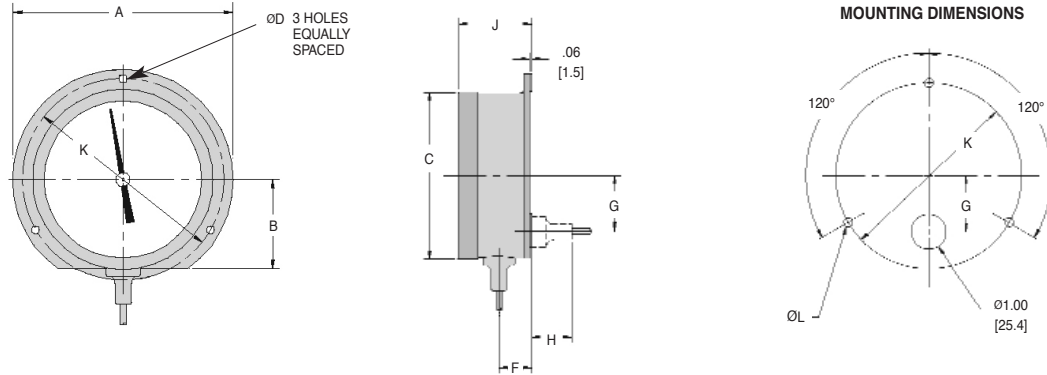

Dial Size	A	B	C	D	F	G	H	J	K	L
4 1/2"	5.88 [149.7]	2.39 [60.7]	4.79 [121.7]	0.22 [5.6]	0.94 [23.8]	1.63 [41.3]	1.41 [35.7]	2.06 [52.4]	5.38 [136.5]	0.25 [6.4]
6"	7.62 [193.6]	3.14 [79.8]	6.29 [159.8]	0.28 [7.1]	0.94 [23.8]	1.63 [41.3]	1.41 [35.7]	2.09 [53.0]	7.00 [177.8]	0.31 [7.9]
8 1/2"	10.25 [260.4]	4.38 [111.1]	8.80 [223.4]	0.28 [7.1]	0.97 [24.6]	1.63 [41.3]	1.41 [35.7]	2.24 [56.8]	9.63 [244.5]	0.31 [7.9]

Flush Mount Hinged Ring Case Models 80345 & 80365

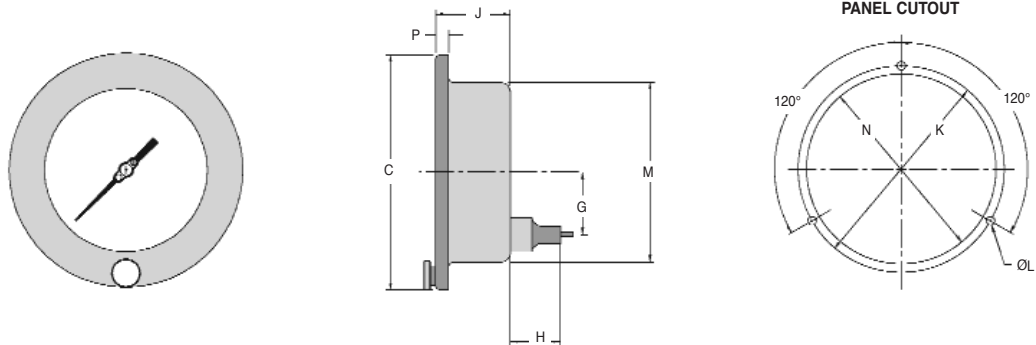

Dial Size	C	G	H	J	K	L	M	N	P
4 1/2"	6.10 [155.0]	1.62 [41.1]	1.31 [33.4]	1.97 [50.0]	5.38 [136.7]	0.22 [5.6]	4.78 [121.4]	4.94 [125.5]	0.34 [8.6]
6"	7.69 [195.3]	1.62 [41.1]	1.31 [33.4]	1.97 [50.0]	7.00 [177.8]	0.28 [7.1]	6.22 [158.0]	6.44 [163.5]	0.34 [8.6]

Standard Ranges (Dual Scale includes both Fahrenheit & Celsius)

Vapor Actuated				
Fahrenheit Scale Range Code	Fahrenheit Scale Range	Celsius Scale Range Code	Celsius Scale Range	Dual Scale Range Code
030	-40° to 150°F	430	-40° to 65°C	230
040	-20° to 100°F	440	-30° to 40°C	240
050	0° to 100°F	450	-20° to 40°C	250
065	0° to 160°F	465	-20° to 70°C	265
100	30° to 180°F	500	0° to 85°C	300
110	30° to 240°F	510	0° to 115°C	310
120	30° to 300°F	520	0° to 150°C	320
145	100° to 350°F	545	40° to 180°C	345
160	200° to 450°F	560	90° to 230°C	360

Liquid Actuated				
Fahrenheit Scale Range Code	Fahrenheit Scale Range	Celsius Scale Range Code	Celsius Scale Range	Dual Scale Range Code
020	-40° to 120°F	420	-40° to 50°C	220
050	0° to 100°F	450	-20° to 40°C	250
060	0° to 160°F	460	-20° to 70°C	260
100	30° to 180°F	495	0° to 80°C	300
110	30° to 240°F	510	0° to 115°C	310
130	50° to 300°F	530	10° to 150°C	330

DIAL THERMOMETERS