

765B/766SS

Low Pressure Gauge • Stainless Steel Case

SPECIALTY GAUGES



766SS shown



- ▶ 2 1/2", 4", 6" Dial Sizes
- ▶ ±1.6% Accuracy (2 1/2", 4")
- ▶ ±2.0% Accuracy (6")
- ▶ Stainless Steel Case

The Trerice **765B/766SS Series** Low Pressure Gauge is designed to accurately measure extreme low pressure conditions. This pressure gauge employs a diaphragm capsule sensing element to measure the low pressure. Case material and wetted parts are either brass or stainless steel.

- Optional features and case style variations available: Please consult the Options & Accessories Section for details.
- For correct use and application of all pressure gauges, please refer to: Pressure Gauge Standard ASME B40.100.

Specifications

Model	Wetted Parts
765B	316L stainless steel diaphragm, brass socket
766SS	316L stainless steel diaphragm, 316L stainless steel socket
Dial Sizes	2 1/2", 4", 6"
Movement	316 Stainless Steel
Connection	Lower male or center back male, 1/4 or 1/2 NPT
Case	304 stainless steel, satin finished, stem-mounted flangeless
Ring	Bayonet type, 304 stainless steel
Window	Clear glass
Pointer	Adjustable via screw on dial face Plain, black finished
Dial Face	Aluminum, white background with black graduations and markings
Accuracy	2 1/2" Dial Size: ±1.6% Full Scale 4" Dial Size: ±1.6% Full Scale 6" Dial Size: ±2.0% Full Scale
Maximum Temperature	765B 140°F (68°C) 766SS 212°F (100°C)

Approximate Shipping Weight

2 1/2" Dial Size:	0.3 lbs [0.14 kg]
4" Dial Size:	1.4 lbs [0.64 kg]
6" Dial Size:	1.9 lbs [0.86 kg]

HOW TO ORDER

Sample Order Number: **766SS 40 02 L W 600**

Model	Dial Size	Connection Size	Connection Location	Units of Measure	Range Code
765B	25 2 1/2"	02 1/4 NPT	L Lower	T Pressure	See Standard Ranges
766SS	40 4"	04 1/2 NPT*	B Back	W Vacuum	
	60 6"				

* Not available with 2 1/2" dial size.

765B/66SS

Low Pressure Gauge • Stainless Steel Case

All dimensions are nominal. Dimensions in [] are in millimeters.

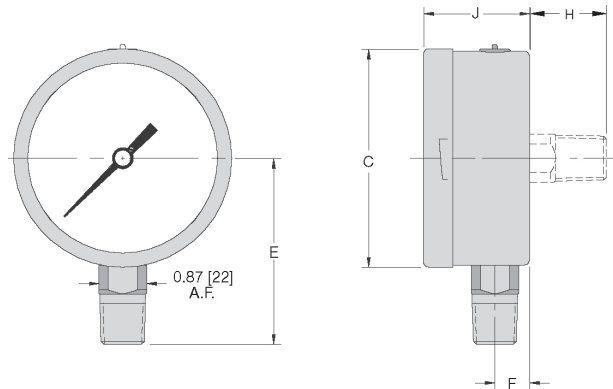

Dial Size	C	E	F	H	J
2 1/2"	2.48 [63]	2.09 [53]	0.43 [11]	1.06 [27]	1.46 [37]
4"	3.98 [101]	3.43 [87]	0.63 [16]	1.38 [35]	1.93 [49]
6"	6.34 [161]	4.76 [121]	0.69 [18]	1.38 [35]	1.97 [50]

SPECIALTY GAUGES

Standard Ranges*

Pressure (T)			
Range Code	Specific Range	Figure Intervals	Minor Divisions
645	0/10 in. H ₂ O	1	0.1
650	0/15 in. H ₂ O	5	0.2
660	0/30 in. H ₂ O	5	0.5
670	0/60 in. H ₂ O	10	1
680	0/100 in. H ₂ O	10	1
690	0/160 in. H ₂ O	20	2
700	0/200 in. H ₂ O	20	2
720	0/300 in. H ₂ O	50	5
652	0/10 oz./in. ²	1	0.1
655	0/15 oz./in. ²	5	0.2
662	0/20 oz./in. ² & 0/34 in.H ₂ O	5	1
667	0/30 oz./in. ²	5	0.5
675	0/60 oz./in. ²	10	1
695	0/100 oz./in. ²	10	1
725	0/160 oz./in. ²	20	2
750	0/250 oz./in. ²	50	5
665	0/3 psi	0.5	0.05
685	0/5 psi	1	0.1
715	0/10 psi	1	0.1

Standard Ranges*

Vacuum (W)			
Range Code	Specific Range	Figure Intervals	Minor Divisions
580	15/0 in. H ₂ O	5	0.2
600	30/0 in. H ₂ O	5	0.5
610	60/0 in. H ₂ O	10	1
620	100/0 in. H ₂ O	10	1
635	200/0 in. H ₂ O	20	2
595	15/0 oz./in. ²	5	0.2
605	30/0 oz./in. ²	5	0.5
625	60/0 oz./in. ²	10	1
633	100/0 oz./in. ²	10	1

* Compound ranges are also available. Please consult factory.